

Deterioration of recycled concrete aggregate under the influence of steady water drainage

Thale S. W. Plessner,¹ ✉
Christian J. Engelsen,^{1,4}
Jacob Mehus,²
Gordana Petkovic³

¹ SINTEF Building and Infrastructure. P.O. Box 123 Blindern. N-0314 Oslo. Norway. Phone: +47 22 96 55. Fax: +47 22 96 57 25. E-mail: christian.engelsen@sintef.no and thale.s.plessner@sintef.no

² Standards Norway. P.O. Box 242. N-1326 Lysaker. Norway. Phone: +47 67 83 87 00. Fax + 47 67 83 87 01. E-mail: jme@standard.no

³ Norwegian Public Roads Administration. P.O. Box 8142 Dep. N - 0033 Oslo Norway. Phone: +47 22 07 35 00. Fax + 47 22 07 38 66. E-mail: gordana.petkovic@vegvesen.no.

⁴ University of Oslo. P.O. Box 1033 Blindern. 0315 Oslo. Phone: +47 22 85 55 17. Fax: +47 22 85 54 41. E-mail: christje@kjemi.uio.no

Abstract

Deterioration from water drainage is an important aspect of durability of recycled concrete aggregate (RCA) in unbound applications such as trenches and road bases. In order to study the impact of steady water drainage on the basic material properties a dynamic column test rig test was designed. The test rig consisted of eight columns placed in two series of four. The pH in the infiltrating water in each series was maintained at pH 4 and 8, respectively. The exposure period lasted almost 20 months. The effect on material properties was determined by testing mechanical strength, density and water absorption. In addition, the concentration of silicon and calcium in the drainage water was measured.

The properties of the RCA changed primarily in two areas: the particle size distribution and the total mass. The change in particle size distribution suggests a deterioration mechanism for the RCA consisting of an initial period of particle break-up followed by a period of equilibrium conditions leading to a stable particle size distribution. The content of acid soluble material in the RCA was reduced from 23 weight % in the untreated aggregate to 12 weight % in the material exposed at pH 4 and 15 weight % in the material exposed at pH 8. There were only minor changes in particle density and mechanical strength. The water absorption remained largely unchanged for RCA exposed at pH 8, but dropped for RCA exposed at pH 4.

After the exposure to water drainage the RCA still satisfies the requirements for mechanical strength, particle density and water absorption set in the Norwegian Guidelines for Road Construction for use as sub-base. However, material loss of about 10 % was registered. The dynamic column rig test experiment presented in this paper is a part of The Norwegian Roads Recycling R&D Program (2002-2005).

1 INTRODUCTION

Recycled concrete aggregate has proved to be a valuable secondary material, especially in road construction. Norwegian full-scale demonstration projects performed since the mid-90s share this experienceⁱ. The material has not yet found its place on the Norwegian market as a building material *product*. However, properties demonstrated in full-scale projects are so good that there is reason to believe that RCA will be used in the future as well. In the Norwegian Public Roads Administration's Manual for Road Construction RCA is included as a road building material. Sub-base in roads and base in pedestrian and bicycle roads are pointed out as the most suitable forms of application. Back-fill material in trenches is also a possible application.

In most applications of recycled concrete aggregates in road structures, the material will be exposed to water drainage. While the volume and rate of drainage of water are low in applications of RCA as road base and sub-base layers, it may be significant in trenches or drainage backfills. Such applications require good knowledge about the deterioration mechanisms and the residual material properties. That was the motivation for starting out the investigation reported in this paper.

The work presented in this paper is a part of the Norwegian Roads Recycling R&D Program (2002 – 2005)ⁱ, which focuses on alternative materials in road construction, including in addition to RCA also asphalt, and shredded tires and cellular glass utilized as lightweight fill materials.

2 RECYCLED CONCRETE AGGREGATE

2.1 Waste volumes and recycling

Norwegian recycled concrete aggregates are produced from the approximately 1,1 million tons of annually generated construction and demolition (C&D) waste, consisting mainly of concrete and masonry. Norway is rich with good rock material so the rubble volume corresponds to only 2 % of the total annual aggregate production. The material is produced by crushing C&D waste, removing the reinforcement by magnetic belts and finally crushing and sieving to a given particle size distribution. The result is a granular material consisting mainly of concrete, rock, masonry, asphalt particles and small amounts of impurities.

On the basis of material composition, in anticipation of European standards, recycled concrete aggregates in Norway have been classified in two main groups: Type 1 (crushed concrete) and Type 2 ("mixed materials", containing some masonry, and some impurities). Each of these types is divided in a class for bound (A) and a class for unbound (B) use. Table 1 presents the main features of these two groups of RCA in Norway.

Table 1. Typical properties of Norwegian recycled concrete aggregateⁱⁱ.

Parameter	Test method	Type 1	Type 2
Particle density (SSD)	EN 1097-6	23-2,6 kg/dm ³	2,3-2,6 kg/dm ³
Water absorption	EN 1097-6	3,5-6,1 %	3,0-9,4 %
Mechanical properties (Los Angles)	EN 1097-2	23,0-34,3	23,8-39,5
Shape – Flakiness index (of mat. > 8 mm)	EN 933-3	10-13	10-15
Organic materials	EN 1744-1	4,1 %	2,4-11,4 %
Chloride content	EN 1744-1	<0,007-0,003 (weight %)	0,003-0,013
Sulphur-containing compounds	EN 1744-1	0,045 % (water soluble) 0,72-0,91 % (acid soluble)	0,04-0,25 % (water soluble)

Concerning deterioration from water, no requirements are set or formulated for recycled concrete aggregate. One is advised to keep the applications above ground water table, mostly due to the documented deteriorating effect of freezing under submerged conditions. Most research work concerning water flow through recycled materials is focused on controlling pollution from the recycled material to the environment. In the case of RCA it is also important to look into the changes of material properties, i.e. water deterioration.

3 EXPERIMENTAL

3.1 Experimental design

To simulate water deterioration of recycled concrete aggregate, a laboratory rig was constructed at the Norwegian Building Research Institute. Recycled concrete aggregate was placed in columns and exposed to a constant water flow. The experimental conditions were selected such that the deterioration process was accelerated. The effect of the water flow was determined by observing changes in the material properties. An introductory literature review identified the following parameters as important for the deterioration of recycled concrete in contact with waterⁱⁱⁱ: grain size, water quality (defined by pH and CO₂ content), water flow rate and temperature. The experimental conditions were carefully chosen based on preliminary tests evaluating the effect of water pH, free CO₂ in the water, water flow rate and water temperature on the deterioration rate.

In order to simplify the investigation, the effect of dry periods was excluded and deterioration of the natural aggregate in the RCA neglected. In addition, only one particle size was included, 10 – 20 mm, which is the most relevant for trenches where water deterioration may be an issue. Fines < 2 mm were removed from the samples before the start of the test, since they would have been washed away within the first days of the test.

3.2 Description of the test rig

The test rig consisted of eight columns, each column containing 40 kg recycled concrete aggregate, particle size 10-20 mm, from manufacturer BA Gjenvinning, see Figure 1. The composition of the aggregate was determined according to European standard prEN 933-11, and is shown in Figure 2.

The water was circulated through the columns at a fixed flow rate. Four columns were kept at pH 4 (an extreme but natural low level) and four columns at pH 8 throughout the test period. pH 4 was maintained by adding a 0,66 M solution of HCl to the water, see Figure 3. In addition, the conductivity of the pH 4 columns was maintained at approximately 300 $\mu\text{S}/\text{cm}$ by adding tap water. pH 8 was maintained by adding tap water to the columns. Water temperature, conductivity, pH, addition of fresh tap water and addition of acid solution were monitored electronically. The L/S ratio calculated from the addition of fresh tap water into the system is shown in Figure 1. The water flow rate was held at 240 l/hour in the columns kept at pH 4 and at 175 l/hour in the columns kept at pH 8.

The tests were started in March 2004 and ended in November 2005; all together the testing period lasted almost 20 months.

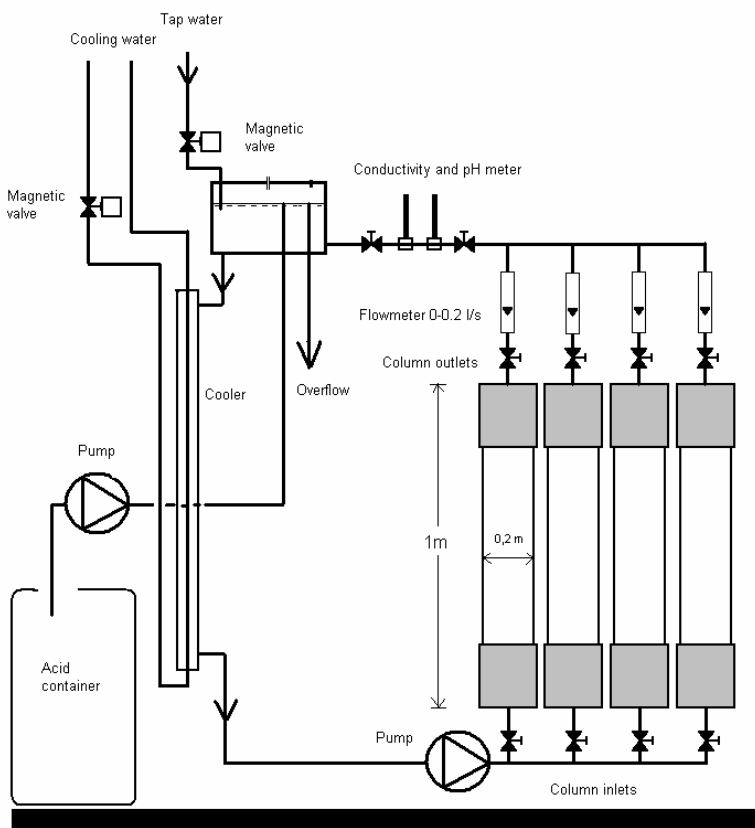

Figure 1. Schematic drawing of the test rig, showing the four columns kept at pH 4. The setup for testing at pH 8 is identical, but there was no inlet for acid and the conductivity was not measured.

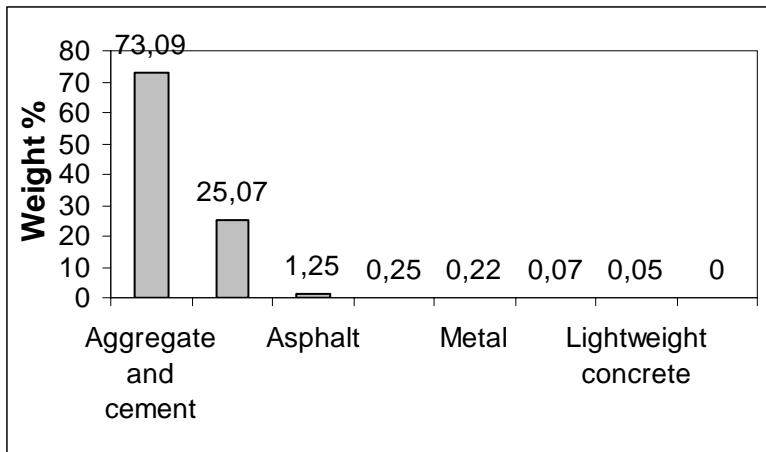

Figure 2. Composition of the RCA.

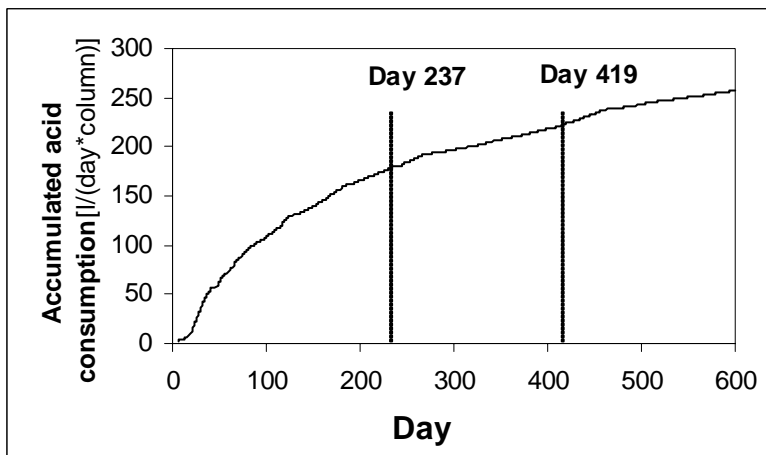

Figure 3. Four columns were kept at pH 4 by adding 0,66 M HCl. The figure shows the accumulated acid consumption per column.

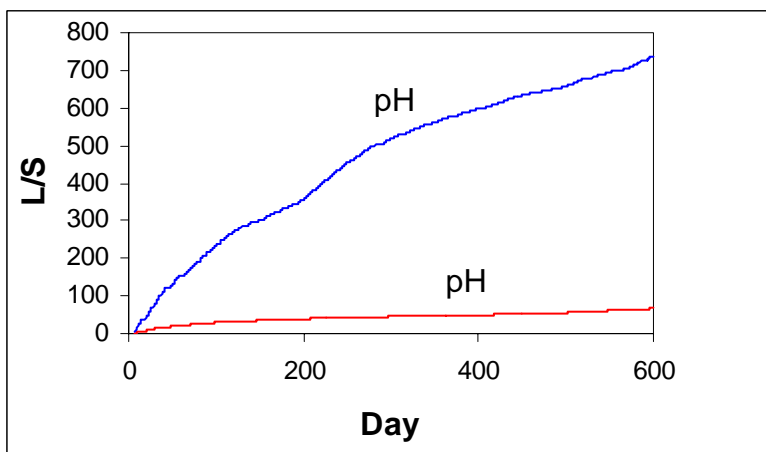

Figure 4. The liquid-solid ratio as function of time.

3.3 Mechanical and chemical tests

On day 237 of the exposure period two columns, one pH 4 column and one pH 8 column, were emptied. Similarly, two pH 4 columns and two pH 8 columns, were emptied on day 419. The remaining two columns were emptied on day 600. The column contents were tested as described in Table 2. The changes in the RCA resulted in a higher percentage of material < 4 mm. In order to carry out some of the laboratory tests, the material < 4 mm had to be removed in some cases. This is shown in Table 2. In addition to standard LA-test, modified versions were performed on the material.

The drainage water was sampled every three to five days starting on day 42 of the test and continuing throughout the test. The 100 ml water samples were filtered and the filtrate conserved by adding 0,5 ml concentrated HNO₃. The calcium and silicon content of the column water samples was determined by flame atomic absorption spectroscopy on a Shimadzu AA-6800. The calcium analysis was performed on diluted samples containing 0,2 g/l La₂O₃ and an additional 0,25 ml concentrated HNO₃ per 50 ml diluted sample. The silicon content was measured without further dilution or other preparation of the samples. Only p.a. grade reagents from Merck were used.

Table 2. Tests performed on the recycled aggregate.

Parameter	Test method	Particle fraction ^{*)}
Particle size distribution	NS-EN 933-1 (sieving method)	All particles
Loose bulk density	NS-EN 1097-3	All particles
Comprimated bulk density	The measurement is performed as described in NS-EN 1097-3 for loose bulk density, except that the container filled with aggregate is vibrated for 60 seconds prior to the registration of aggregate volume.	All particles
Voids	NS-EN 1097-3	All particles
Particle density	NS-EN 1097-6	1) All particles 2) Particles > 4 mm
Water absorption	NS-EN 1097-6	1) All particles 2) Only particles > 4 mm
Los Angeles test (mechanical strength)	NS-EN 1097-2	1) 10-14 mm (standard) 2) Particles > 4mm (modified LA-test I) 3) Particles > 2 mm (modified LA-test II)
Solubility in perchloric acid	NT Build 437	All particles

*) Some tests were performed on aggregates including particles smaller than 4 mm and on aggregates where the particles smaller than 4 mm had been removed prior to testing.

4 RESULTS AND DISCUSSION

4.1 Accelerated testing

The testing procedure primarily provides acceleration due to a constant water flow with no dry periods. The particle size distribution, 10-20 mm, of the RCA was chosen within the realistic range and so had little accelerating effect. The experiment was run at somewhat higher temperatures (15-20 °C) than found in a realistic setting, the ground water temperature in Norway is typically < 8 °C. However, a previous study has shown that the effect of raising the temperature from 5-45 °C is small^{iv}. Similarly, preliminary experiments performed as part of this study showed that the effect of raising the water temperature from 17 °C to 25 °C was smallⁱⁱⁱ. The accelerating effect of temperature was therefore deemed negligible compared to the effect of the water flow rate. Changes in the CO₂ content had to be excluded from the test for practical reasons.

A rough approximation of the acceleration level is that one-year exposure time corresponds to 365 years in the middle zone and 24 years in the bottom zone of a trenchⁱⁱⁱ. The calculated correlation between exposure time under accelerated conditions and equivalent exposure under normal conditions in a trench is shown in Table 3.

Table 3. Calculated correlation between exposure times under accelerated conditions and equivalent exposure under normal conditions in a trench.

Exposure time at accelerated conditions [days]	Equivalent exposure time in a trench at normal conditions [years]	
	Middle	Bottom
0	0	0
237	237	16
419	419	28
600	600	39

When the RCA is used as sub-base in a road the equivalent exposure time at normal conditions would be much higher than the equivalent exposure time estimated for a trench. This is because the sub-base material is usually covered by asphalt and is therefore, unlike the trenches, largely protected from draining rainwater or melting snow.

4.2 Changes in mechanical and physical properties

The particle size distribution of the RCA is shown in Figure 5. The particle size distribution of the untreated material is estimated from the measurement performed before removal of particles with diameter < 2 mm. The recalculation was necessary because the columns were filled with RCA after removal of particles with diameter < 2 mm.

The RCA treated at pH 8 contained more fines than the untreated aggregate. The material exposed at pH 4 contained more fine particles than the material exposed at pH 8. At both pH levels the particle size distribution changed only minimally in the period between day 237 and day 600. It seems that the RCA particles went through an initial period of degradation that caused the particles to break up into smaller particles. The initial break-up period was then followed by a period of comparatively stable particle size distribution. The overall break-up of particles was more pronounced in the acidic environment.

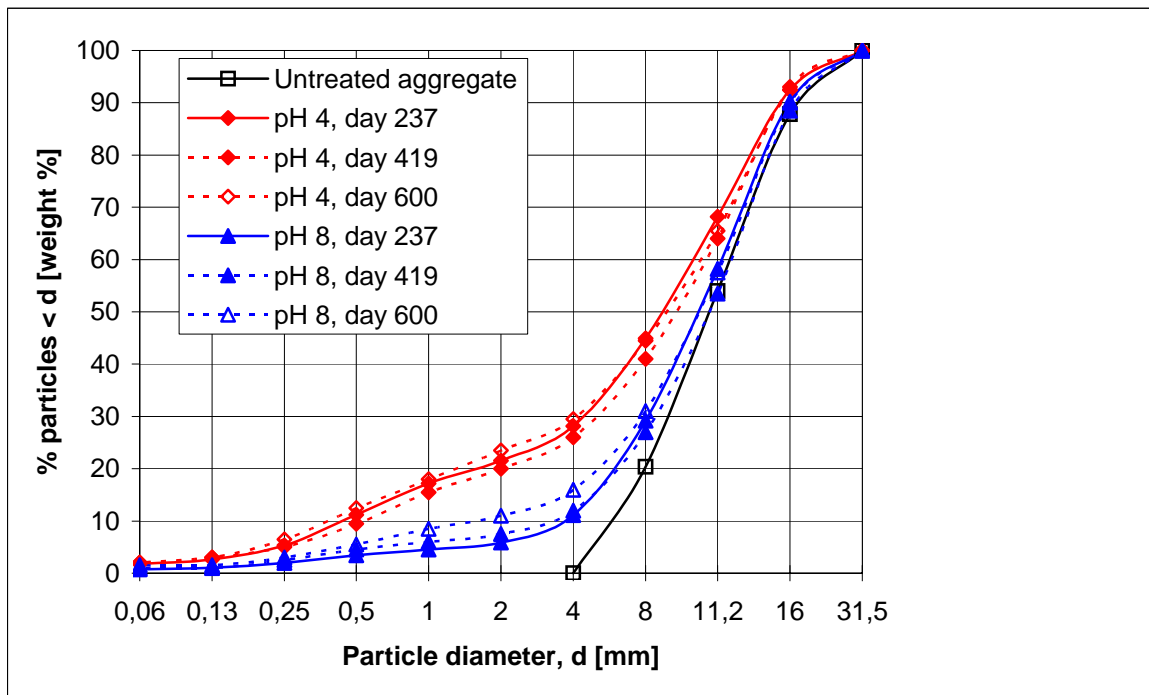

Figure 5. The particle size distribution of the RCA. Each curve is a mean value of to parallel measurements. The particle size distribution of the untreated material is estimated from the measurement performed before removal of particles with diameter < 2 mm (modified LA test II).

The Los Angeles value was measured to be 38 for the untreated material. It remained between 32-38 throughout the exposure period, see Figure 6.

The oven dry particle density increased somewhat during the exposure period, see Figure 7. The same tendency could be observed for the surface dry particle density.

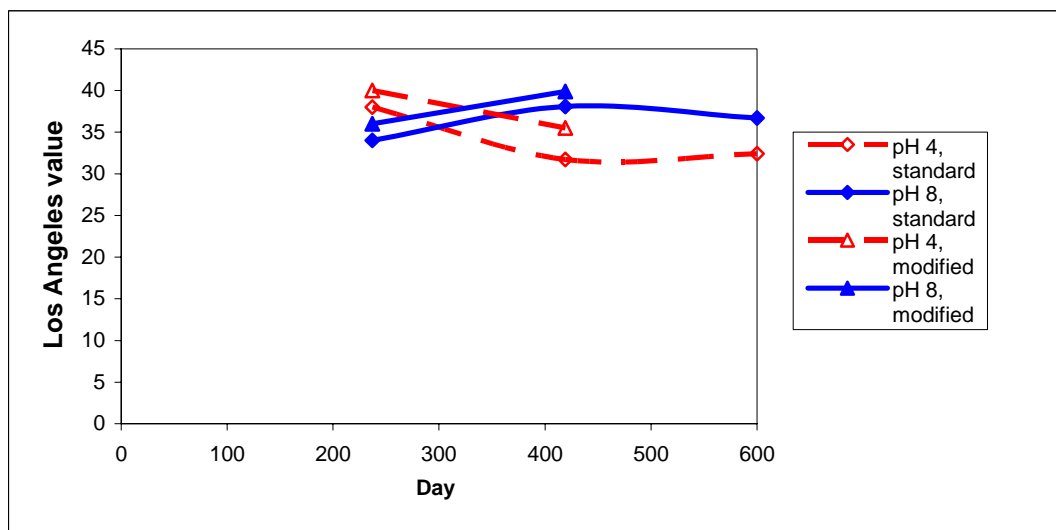

Figure 6. The Los Angeles value for the RCA. The standard LA test was performed on the 10-14 mm fraction, while the supplementary modified LA-test was performed after removing the particles smaller then 4 mm by wet sieving of the material. The untreated material was tested after removal of all particles < 2 mm giving an LA-value of 37.

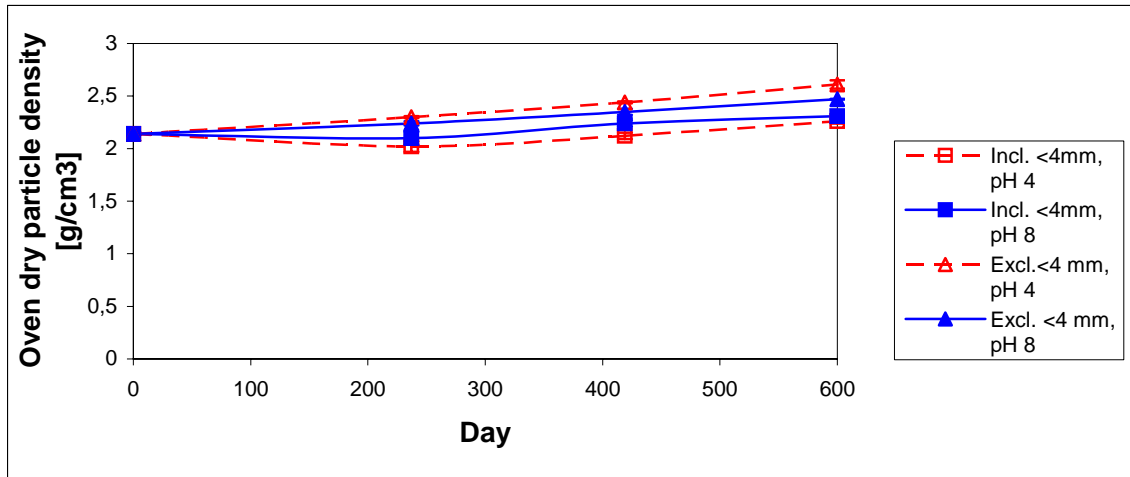

Figure 7. The oven dry particle density of the RCA (mean values of three measurements).

The bulk density increased slightly during the first half of the exposure period at pH 4 and decreased somewhat during the second half, see Figure 8. The material exposed at pH 8 remained at a stable bulk density during the initial part of the exposure period, increasing somewhat towards the end. The water absorption remained largely unchanged for the RCA exposed at pH 8 but dropped substantially for the RCA exposed at pH 4, see Figure 9.

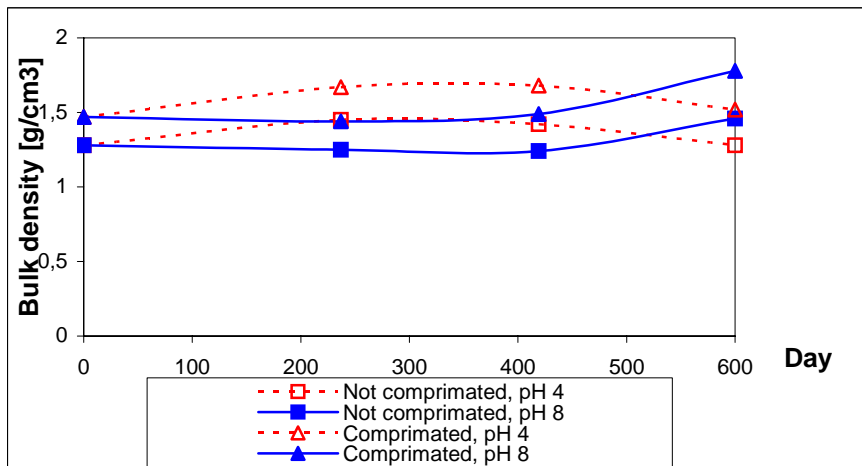

Figure 8. The bulk density of the RCA (mean values of two measurements).

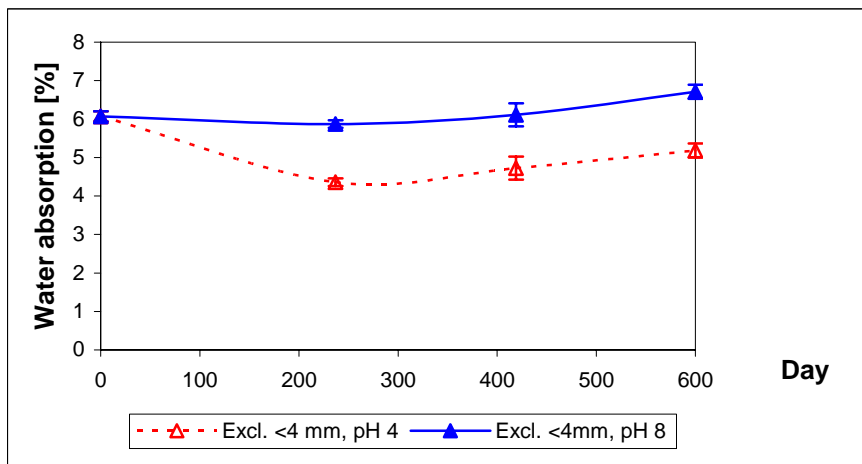

Figure 9. The water absorption of the RCA (mean values of three measurements).

4.3 Comparison of physical and mechanical properties with construction guidelines

The Norwegian guidelines for road construction^v put no other requirements on the properties for materials used as filling material in trenches than that they do not crush to easily and that they are not harmful to the pipes.

The RCA meets the requirements throughout the exposure period, as set down by the Norwegian guidelines for road construction, for particle density, water absorption and maximum amount of fines, see

Table 4. The LA value is somewhat high for upper sub-base, but meets the requirements for lower sub-base. The uniformity index is initially too low for use in upper sub-base, and only barely meets requirements for lower sub-base.

Table 4. Requirements for RCA used as road base^v and comparison with values observed in this study.

Parameter	Requirement	Observed value
LA-value, upper sub-base	≤ 35	pH 4: 32-38, pH 8: 34-38
LA-value, lower sub-base	≤ 40	pH 4: 32-38, pH 8: 34-38
Uniformity index C_u - upper sub-base	≥ 15	pH 4: 4,5-27, pH 8: 3-7
Uniformity index C_u - lower sub-base	≥ 5	pH 4: 4,5-27, pH 8: 3-7
Oven dry particle density ²⁾	$> 2 \text{ g/cm}^3$	Incl. < 4mm: 2-2,3, Excl. < 4 mm: 2,1-2,6
Surface dry particle density ²⁾	$> 2,1 \text{ g/cm}^3$	Incl. < 4mm: 2,1-2,5, Excl. < 4 mm: 2,3-2,8
Water absorption ²⁾	$< 10 \%$	Incl. < 4mm: 5,7-7,1

1) (The weight of material with diameter < 0,063 mm)/(the weight of material with diameter < 20 mm)*100%.

2) RCA of Type 1B: Crushed concrete and natural aggregates > 94%.

4.4 RCA material loss

The acid soluble material in the aggregate was reduced from 23 weight percent in the untreated material to 12 weight percent in the material exposed at pH 4 and 15 weight percent in the material exposed at pH 8, see Figure 10. The mass loss was higher at pH 4 than at pH 8, and was, at both pH levels, most likely primarily due to dissolution of the cement phase.

Unexpectedly, the content of acid soluble aggregate increased at the end of the exposure period. The increase is probably due to inhomogeneity in the material in the column, although much care was taken to avoid inhomogeneity, both before filling and after emptying of the columns.

Unfortunately the mass of the material in each column was not weighed after the emptying of the column, but assuming that material disappeared from the columns only due to dissolution of the acid soluble material and not because natural aggregate particles were washed out or dissolved, the reduction in acid soluble cement can be used to estimate the mass and volume loss, see Table 5. The calculated loss probably underestimates the real mass loss since it was shown in a preliminary study that fine particles are easily washed out^{vi}.

Table 5. Cumulative loss of mass in the recycled concrete aggregate.

Exposure time [days]	Calculated RCA loss [weight %]		Calculated RCA loss ¹⁾ [volume %]	
	pH 4	pH 8	pH 4	pH 8
237	11	6	6	4
419	16	12	9	8
600	12	9	8	5

1) The volume reduction is calculated from the measured comprimated bulk density at each exposure duration and the calculated weight loss.

The concentration of silicon and calcium in the drainage water was found to be constant throughout most of the exposure period at both pH levels, see Figure 11. The calcium level dropped somewhat towards the end of exposure period at pH 4 but regained its initial value at the very end. The calcium and silicon levels most likely mainly reflect the equilibrium concentrations at the given pH and temperature and chosen conductivity. The observed drop in calcium level can probably be attributed to a simultaneous drop in conductivity from 300 to 200 S/cm that was observed in the pH 4 rig during the same time period. At day 500 the conductivity rose to 300 S/cm and remained at this level for the remaining exposure period and at the same time the calcium level in the drainage water rose towards its previous level.

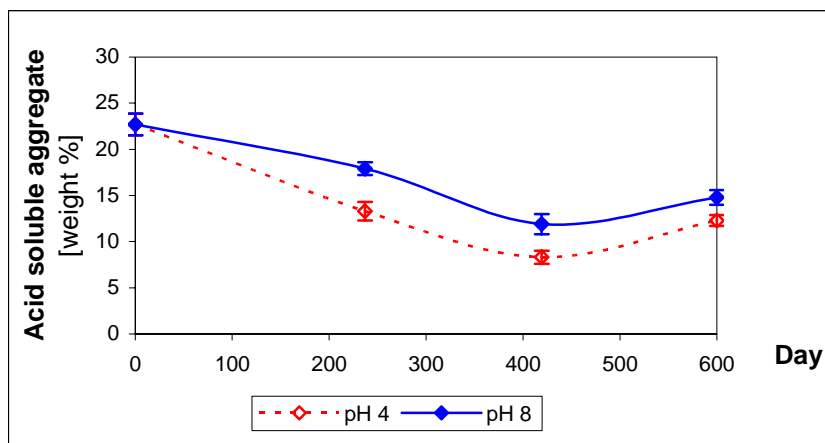

Figure 10. The acid solubility of the RCA (mean values of four measurements), basis for the calculation of weight loss in Table 2

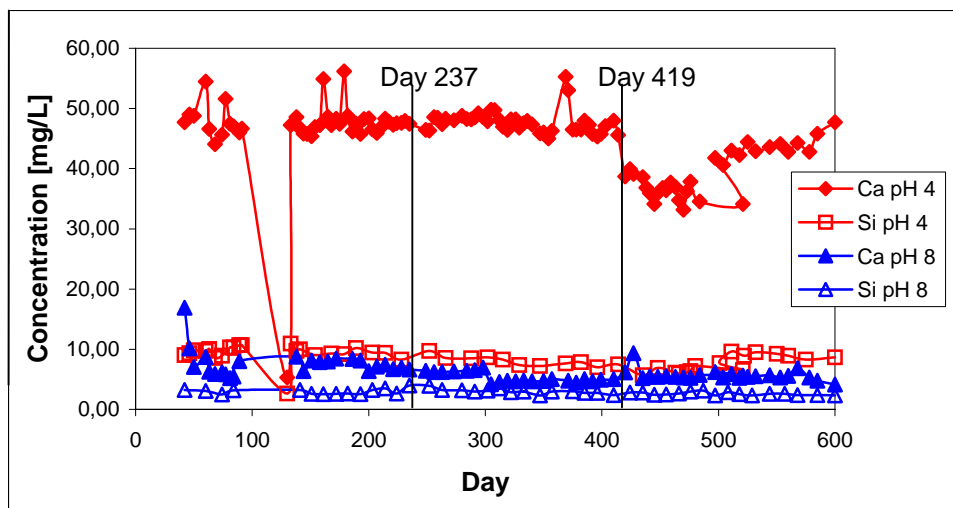

Figure 11. The calcium and silicon concentration in the drainage water.

5 CONCLUSIONS

At the beginning of this investigation, the expected effect of water drainage was a material with higher porosity and water absorption and poorer mechanical properties to be measured as higher LA values. Instead, it was observed that the cement paste dissolved and the RCA particles broke up, but only minor changes in particle density and mechanical strength resulted. The water absorption was reduced somewhat at pH 4, but remained almost level at pH 8.

The properties of the RCA mainly changed in to areas: the particle size distribution and the total mass.

The change in particle size distribution suggests a deterioration mechanism for the RCA consisting of an initial period of particle break-up followed by a period with equilibrium conditions leading to a stable particle size distribution. The effect was more pronounced in an acidic environment.

The content of acid soluble material in the RCA was reduced from 23 weight % in the untreated aggregate to 12 weight % in the material exposed at pH 4 and 15 weight % in the material exposed at pH 8.

After the exposure to water drainage the RCA still satisfies the requirements for mechanical strength, particle density and water absorption set in the Norwegian Guidelines for Road Construction for use as sub-base. However, material loss of about 10 % was registered.

6 REFERENCES

[ⁱ] Norwegian Public Roads Administration 2002. www.gjenbruksprosjektet.net (in Norwegian)

[ⁱⁱ] Myren, S. and Mehus, J.: "Material declaration of recycled concrete aggregate. Certification scheme testing.", Norwegian Roads Recycling R&D Program, Project report nr 13, NPRA Technology report 2431, 2006.

[ⁱⁱⁱ] Groth, J.B. 2003. Chemical deterioration of recycled concrete aggregate. Diploma project NTNU Trondheim & Report 04/DP3 Norwegian Roads Recycled Materials R&D Program. Oslo: NPRA. (in Norwegian)

[^{iv}] Rombén, L. Aspects on testing methods for acid attacks on concrete - further experiments. CBI report 9:79, Swedish Cement and Concrete Institute, 1979.

[^v] Norwegian Public Roads Administration 2004. Manual 018 Road Construction. Oslo: NPRA. (in Norwegian)

[^{vi}] Mehus, J., Skaare, L., Myhre, Ø. 2002. Unbound use of recycled concrete aggregate in utility trenches. RESIBA report 06/2002. Oslo: Norwegian Building Research Institute. (in Norwegian)