

1. * Dimensions
2. Theoretical weight of items galvanized

				BO 211.00.00.000 AD			
Chan. Sheet	N° Doc.	Signed	Date	APM-80P Aggregate drawing	Sheet	Weight	Image scale
Worked out	Kurbanov		04.06.18			1065	1:20
Checked	Sysaev				Sheet 1	Sheets	3
Technical control	Fedorova				OAO "Zavod Prodmash"		
Norm. control	Zatonskaya			Format A3			
Confirmed	Nemov						

BO 211.00.00.000

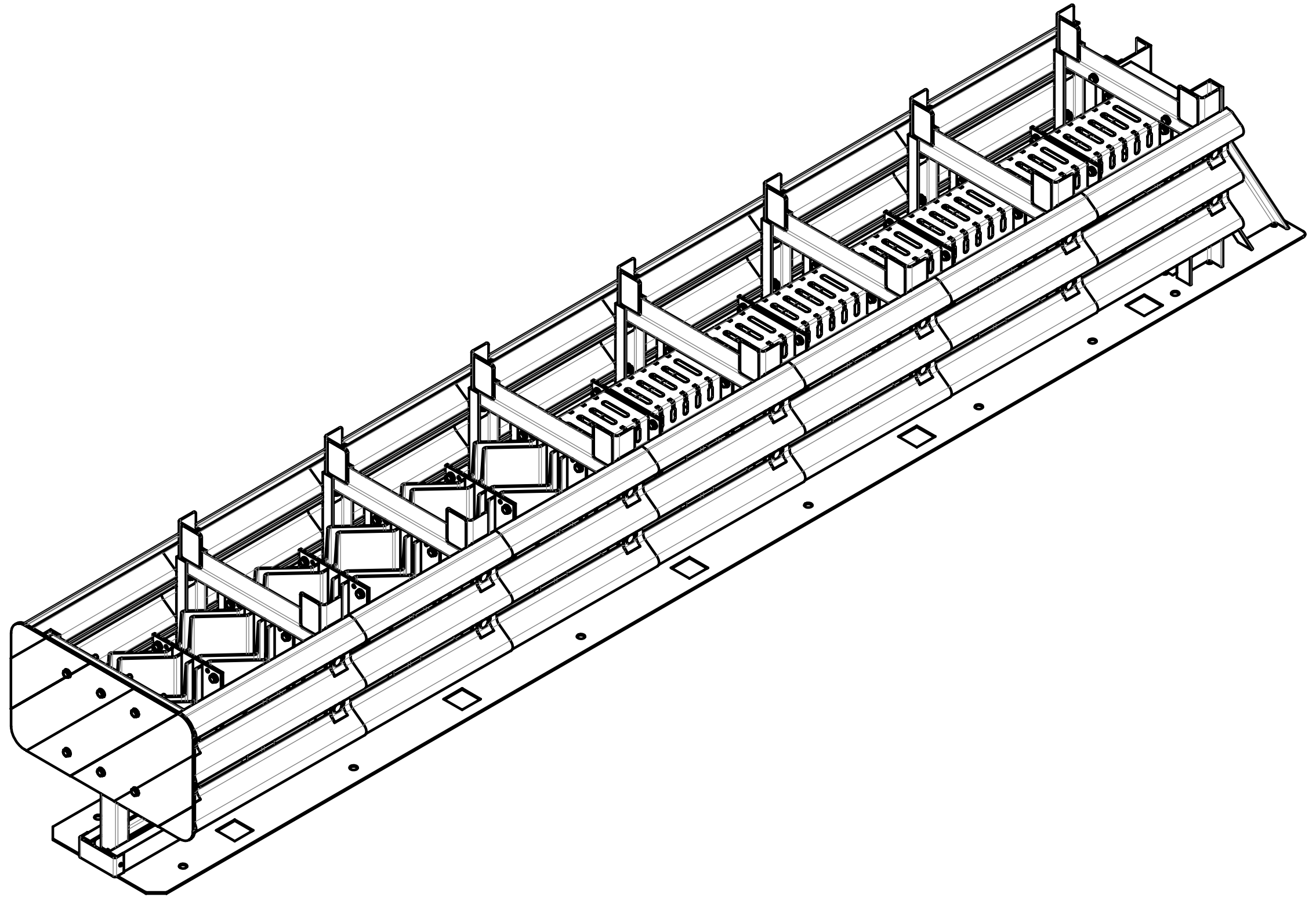

BO 211.00.00.000

Sheet

2

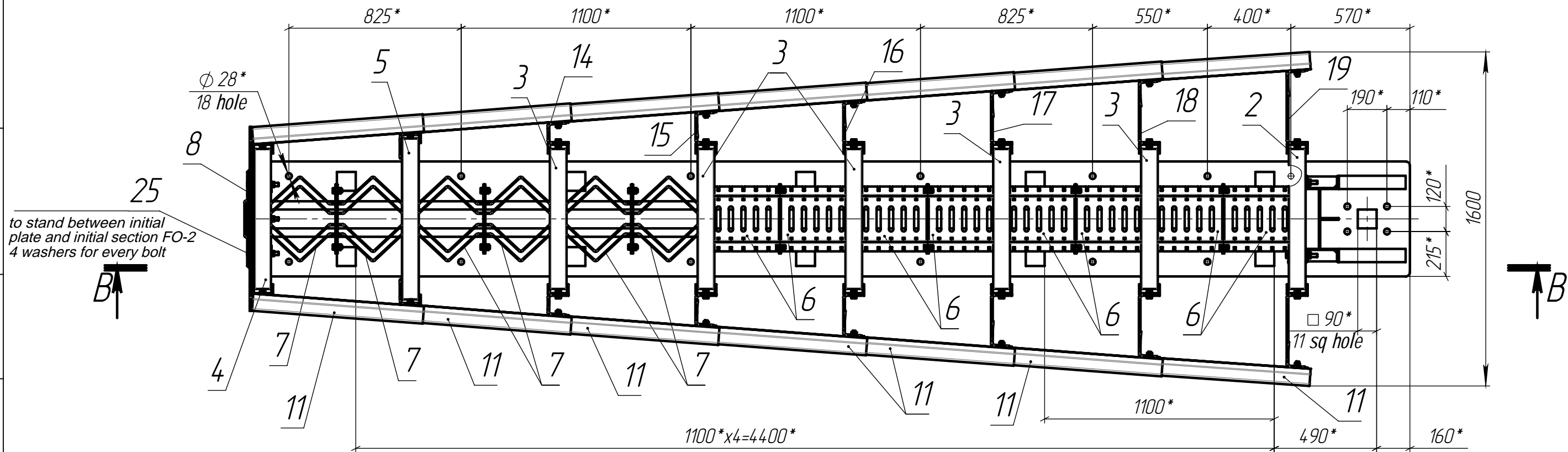
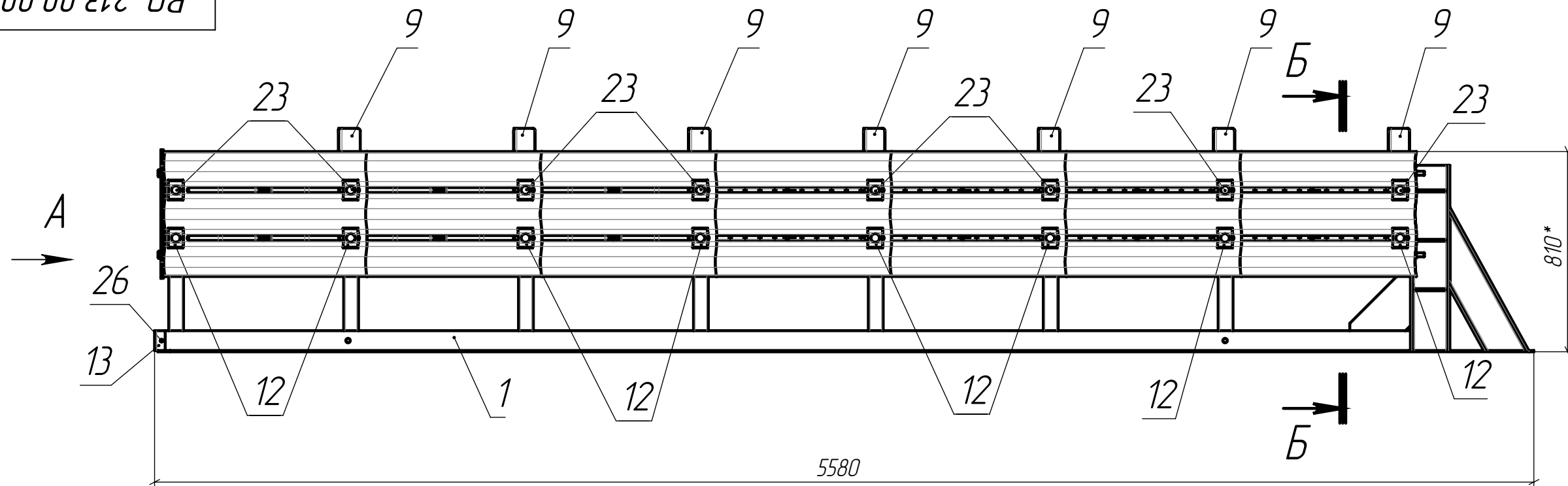

1. * Dimensions
2. Theoretical weight of items galvanized

					BO 213.00.00.000 AD			
Chan.	Sheet	N° Doc.	Signed	Date	APM-80W Aggregate drawing	Sheet	Weight	Image scale
Worked out		Kurbanov		04.06.18			1170	1:20
Checked		Sysaev				Sheet 1		Sheets 3
Technical control		Fedorova						
Norm. control		Zatanskaya						
Confirmed		Nemov						

BO 213.00.00.000 AD

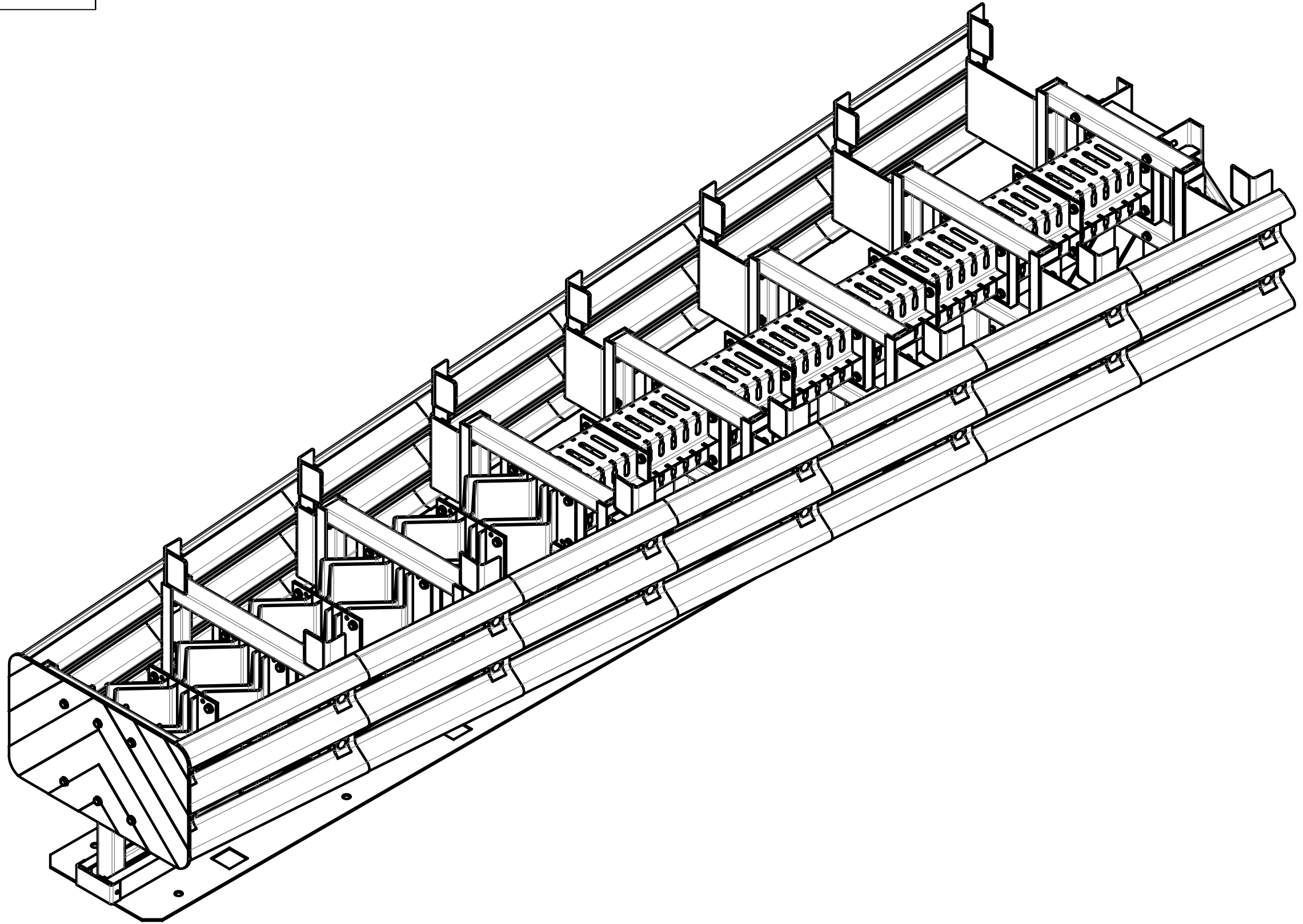

BO 213.00.00.000 AD

Sheet
2