

BUREAU VERITAS
Certification

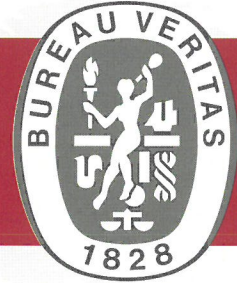

CERTIFICATE OF CONSTANCY OF PERFORMANCE

Certificate nb: **1035-CPR-ES1055474-95**

In compliance of the Regulation No 305/2011 of the European Parliament and of the Council of 9 March 2011 laying down harmonized conditions for the marketing of construction products, it has been stated that the product:

VEHICLE RESTRAINT SYSTEM - SAFETY BARRIER SINGLE STEEL GUARDRAIL "BMS4PR-N2"

The characteristics are detailed in the attached annex

Manufactured by:

ROAD STEEL ENGINEERING, S.L.

Produced in:

1. HIASA. Polígono industrial de Cancienes 33470 Corvera, Asturias, España
2. ÇEPAŞ. İstanbul Yolu 25.Km, Saray Mahallesi 175. Sokak No:2,2/A, Kahramankazan, Ankara, Turquía
3. GONVARRI MS COLOMBIA S.A.S., Calle 86 N° 45-90 Itagüí - Colombia

They are submitted by the manufacturer to factory production control established at the standard EN 1317-5:2007+A2:2012 Road restraint systems. Part 5: Product requirements and evaluation of conformity for vehicle restraint systems, and the initial type testing by accredited laboratory of samples taken at the factory.

The notified body BUREAU VERITAS CERTIFICATION has performed the initial inspection of the factory and of the factory production control and performs the continuous surveillance, assessment and approval of the factory production control established in the harmonized standard concerned.

This certificate attests that all provisions concerning the attestation of factory production control described in the Annex ZA of the harmonised standard were applied and it authorizes the manufacturer or its agent to fix the CE marking.

This certificate remains valid as long as the conditions laid down with the harmonised standard concerned or the manufacturing conditions in the factory or the FPC itself are not modified significantly.

Date of initial issuing: Madrid, 28/05/2019



Mónica Botas
Certification Manager

Bureau Veritas Iberia, S.L., Edificio Caoba. C/ Valportillo Primera 22-24 Polígono Industrial La Granja, 28108 – Alcobendas (MADRID). Notified body 1035



TECHNICAL DATA SHEET ANNEXED TO CERTIFICATE
OF CONSTANCY OF PERFORMANCE
Nº: 1035-CPR-ES1055474-95
Date of approval: 28/05/2019

Barrier
BMS4PR-N2

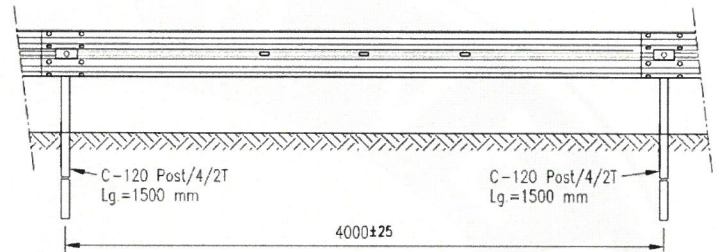
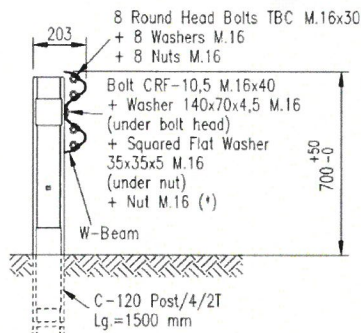

CROSS SECTION

ELEVATION

Dimensions in mm

STANDARDS	PERFORMANCE PARAMETERS	ACCORDING TO UNE-EN 1317-2
UNE EN 1317-1 UNE EN 1317-2 UNE EN 1317-5	a) Performance Level b) Impact Severity Level c) Normalized Working Width d) Normalized Dynamic Deflection e) Normalized Vehicle Intrusion f) Resistance to snow removal	N2 A W _N = 1,0 m (W3) D _N = 1,0 m Not applicable Class 3
DETACHED PIECES:	Totally detached elements having a solid mass > 2,0 Kg: NO Totally detached elements having a solid mass > 0,5 Kg: NO	
SOIL DESCRIPTION:	Controlled soil ZA-20 Compactness average 99 % Result Static Post Test according to UNE 135124: OK	
HAZARDOUS SUBSTANCES:	NPD	
OBSERVATIONS:	This barrier forms a family of barriers, according to section 4.7 of the UNE-EN 1317-2 standard, with the simple steel guardrail "BMS2PR-N2" (Certificate of Constancy of Performance: 1035-CPR-ES1055474-94).	
INITIAL TYPE-TEST LABORATORY:	FUNDACIÓN CIDAUT, Valladolid (Spain)	
VEHICLE IMPACT TEST CODES:	E18-1386	TB32
MATERIALS:	Steel UNE-EN 10025	DURABILITY: Hot Dip Galvanizing. UNE-EN ISO 1461, UNE-EN ISO 14713