



## Statens vegvesen

Meiser Strassenausstattung GMBH  
Edmund-Meiser-Straße 3  
66839 Schmelz-Limbach  
Tyskland

Jaroslav Cholewinski

Behandlende enhet: Vegdirektoratet	Saksbehandler/telefon: Fredrik Nyberg / 40035038	Vår referanse: 24/2207-14	Deres referanse:	Vår dato: 08.03.2024
---------------------------------------	---	------------------------------	------------------	-------------------------

### Samsvarsgodkjenning av Easy Rail xs 4.0 vegrekkverk

Det vises til søknad vedrørende samsvarsgodkjenning av Easy Rail xs 4.0 vegrekkverk fra MEISER Strassenausstattung GmbH med journalnummer 23/10106-75 datert 17.10.23.

Søknaden inneholder:

- Testrapport nummer PSG 109 (TB11 test) datert 07.03.14 av Easy Rail xs 1.33 og testrapport nummer PSG 107 (TB32 test) datert 07.03.14 av Easy Rail xs 4.0. Rekkverket er testet av TSR Engineering GmbH testsenter.
- Tegning nummer MST-00002091 datert 17.10.23 og monteringsbeskrivelse av rekkverket.
- Produktsertifikat nummer 0531-CPR-1317-2923 utstedt av TÜV SÜD akkreditert teknisk kontrollorgan.

Easy Rail xs 4.0 er et stålrekkverk med føringssskinne i A, B, AF eller BF profil montert på C-stolper. Rekkverket installeres i løsmasser, eller i asfalt eller betong ved å bore hull med diameter på 30 cm som stolpene settes ned i. Easy Rail xs 4.0 har en stolpeavstand på 4,0 meter, en bredde på 0,18 meter og en høyde på 0,75 meter. Rekkverket produseres av MEISER Straßenausstattung GmbH.

Easy Rail xs 4.0 vegrekkverk er i samsvar med nasjonale krav gitt i vegnormal N101. I henhold til byggeveareforordningen 305/2011 har produktet gjennomgått tredjepartskontroll. Produktets ytelser fremgås i produktsertifikatet 0531-CPR-1317-2923. Rekkverket tilfredsstiller kravene til styrkeklasse N2 med arbeidsbreddeklasse W4, skadeklasse A og snøklasse 3.

Med grunnlag i overnevnte gis herved adgang til bruk av Easy Rail xs 4.0 vegrekkverk på offentlig veg i Norge.

Postadresse  
Statens vegvesen  
Vegdirektoratet  
Postboks 1010 Nordre Ål  
2605 LILLEHAMMER

Telefon: 22 07 30 00  
firmapost@vegvesen.no  
Org.nr: 971032081

Kontoradresse  
Innspurten 11C  
0663 OSLO

Fakturaadresse  
Statens vegvesen  
Fakturamottak DFØ  
Postboks 4710 Torgarden  
7468 Trondheim

Leverandøren skal levere monteringsbeskrivelse til brukere for å sikre kvalitet av installasjon og fremtidig vedlikehold. Easy Rail xs 4.0 skal monteres i henhold til produsent/leverandørens monteringsbeskrivelse. Vegnormal N101 legges til grunn for valg, bruk, plassering og innfesting av rekkverket og rekkverksender.

Vegdirektoratet publiserer en rekkverksliste med tilhørende gyldige dokumenter på vegvesen.no. Vegdirektoratet forbeholder seg retten til å endre eller tilbakekalle samsvargodkjenningen. Eventuelle endringer i produktets utforming eller materiale vil ugyldiggjøre denne godkjenningen.

Med hilsen

Sigmund Reinsborg Log  
Seksjonssjef

Fredrik Nyberg

*Dokumentet er godkjent elektronisk og har derfor ingen håndskrevne signaturer.*

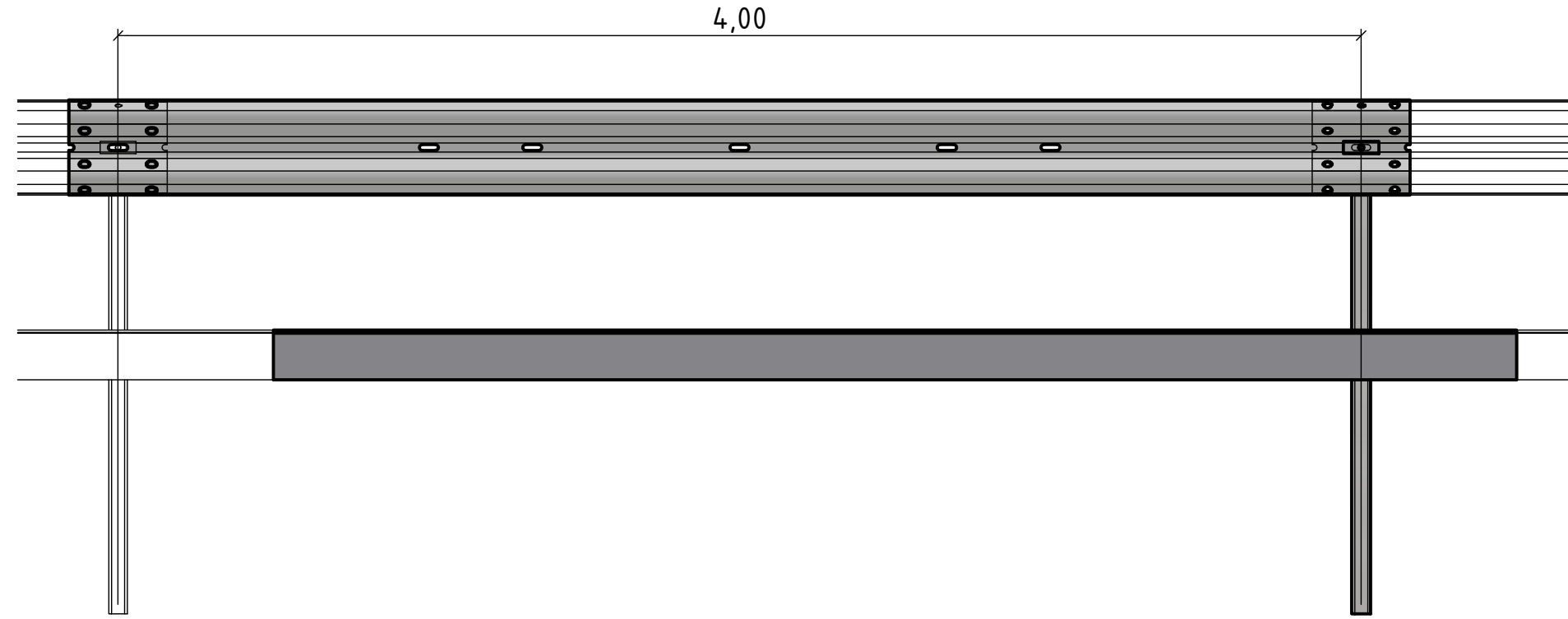
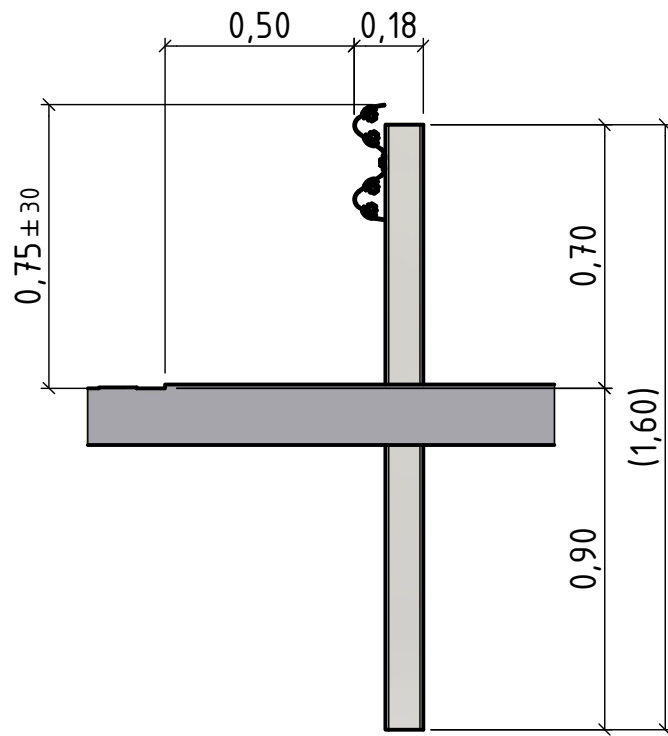

← Fahrtrichtung  
driving direction



<b>MEISER</b>  <b>Straßenausstattung</b> MEISER Straßenausstattung GmbH Edmund Meiser Straße 3 D-66839 Schmelz-Limbach Tel: +49 (0) 6887/9590-100 Fax: +49 (0) 6887/9590-188 E-mail: strassenausstattung@meiser.de Internet: strassenausstattung.meiser.de	Zeichnungsnr. Meiser drawing n° MEISER MST-00002091	proALPHA Nr./ proALPHA no: ko000514	Revision: -
	Datum/ date 17.10.2023 Name/ name Marina Maus	Bezeichnung/ Description : <b>Easy-Rail XS 4.0</b> Easy-Rail XS 4.0 Profil A LL/LL, Ausführung rechts profile A LH/LH, right side <b>Easy-Rail XS</b>	
Maßstab/ scale 1 : 20 Format/ size A3	Alle Maßangaben sind in Meter angegeben		Richtliniendokument (wenn vorhanden) Guidelines document (if available) keine Angabe
			Blatt/ Sheet: 1 von 2

Dieses Dokument darf ohne die schriftliche Genehmigung von "MEISER Straßenausstattung" weder reproduziert, noch Dritten zugänglich gemacht werden, noch zu eigenen Zwecken verwendet werden.

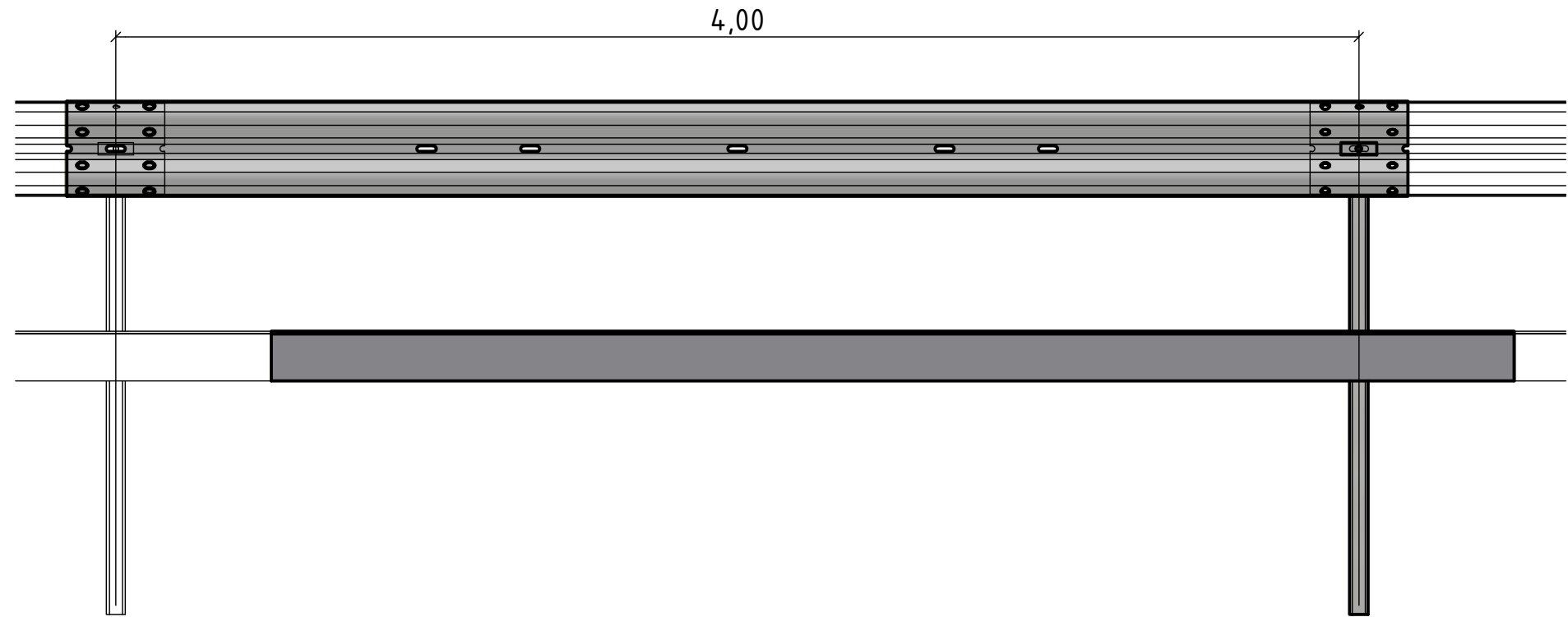
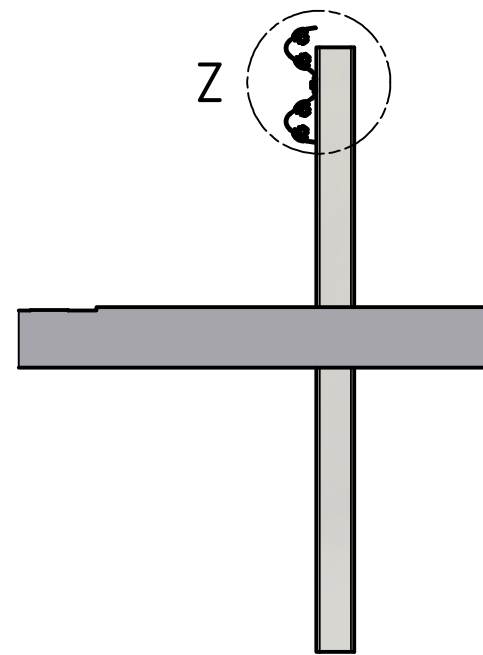

Fahrtrichtung  
driving direction

Z ( 1 : 5 )

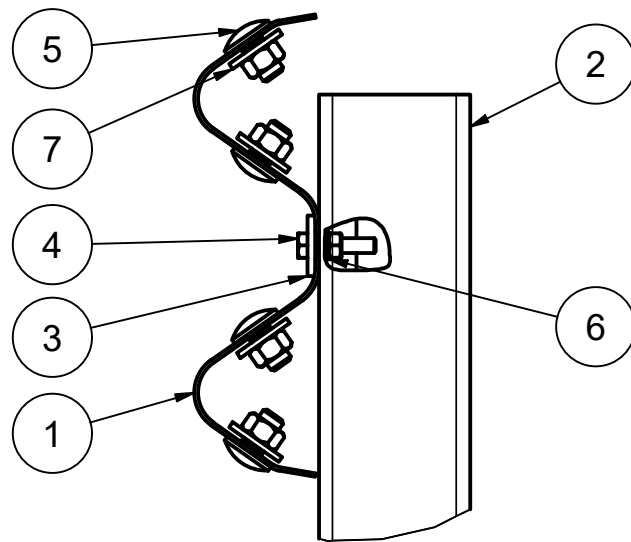

Pos.	Anz.	ProAlpha	Zeichnungsnr.	Bezeichnung	Description	Werkstoff	Gewicht	MEISER 			Zeichnungsnr. Meiser drawing n° MEISER	MST-00002091	proALPHA Nr./ proALPHA no:	ko000514	Revision:
1	1	rv020108	MST-00001825	Schutzplankenholm Profil A	Safety barrier beam profile A	S355JR	39,78 kg	<b>Straßenausstattung</b> MEISER Straßenausstattung GmbH Edmund Meiser Straße 3 D-66839 Schmelz-Limbach Tel: +49 (0) 6887/9590-100 Fax: +49 (0) 6887/9590-188 E-mail: strassenausstattung@meiser.de Internet: strassenausstattung.meiser.de Maßstab/ scale 1 : 20 Format/ size A3			Datum/ date	17.10.2023	Name/ name	Marina Maus	Bezeichnung/ Description :
2	1	rv430311	MST-00002089	Pfosten Easy-Rail XS	Post Easy-Rail XS	S355JR	12,15 kg				Gezeichnet/ drawn				Easy-Rail XS 4.0
3	1	rv001010	MST-00000027	Decklasche M10	Butt Plate M10	S235JR	0,18 kg				Geprüft/ audited				Easy-Rail XS 4.0
4	1	rv004054	MST-00000046	Sechskantschraube mit Mutter, M10x45, 8.8, 8	Hexagon bolt with nut, M10x45, 8.8, 8		0,05 kg				Alle Maßangaben sind in Meter angegeben			Profil A LL/LL, Ausführung rechts profile A LH/LH, right side	
5	8	rv018511	MST-00001567	HRK-Schraube mit Mutter, M16x30, 8.8	HRK screw with nut, M16x30, 8.8		0,13 kg							Easy-Rail XS	
6	1	rv004060	MST-00000244	Scheibe 10	Flat washer 10	S235JR	0 kg							Richtliniendokument (wenn vorhanden) Guidelines document (if available)	keine Angabe
7	8	rv004031	MST-00000048	Scheibe 18	Flat washer 18	S235JR	0,03 kg								

## Compliance letter for Easy Rail xs 4.0 safety barrier

At the request of the applicant, the following shortened English version of the Norwegian compliance letter 24/2207-14 is issued. In case of any discrepancy between the English and the Norwegian approval letter, the Norwegian version should act as the original.

*Ref. to MEISER Strassenausstattung GmbH request of approval for Easy Rail xs 4.0 safety barrier with journal number 23/10106-75 dated 17.10.23.*

*Easy Rail xs 4.0 safety barrier complies with national requirements in the N101 specification and it has undergone third party control according to the Construction Products Regulation (CPR) 305/2011. Product performances are shown in product certificate 0531-CPR-1317-2923.*

*In accordance with test results provided, Easy Rail xs 4.0 satisfies the requirements for containment class N2 with working width class W4, impact severity level A and resistance to snow removal class 3.*

*Based on the above, it is given hereby access to the use of Easy Rail xs 4.0 safety barrier on public Norwegian roads.*

*The supplier shall provide user instructions to ensure quality of installation and future maintenance. Easy Rail xs 4.0 shall be installed in accordance with the installation's instruction given from the producer. N101 specification shall be used as basis for the choice, use and installation of the safety barrier.*

*The Norwegian Road Directorate publishes a list of compliant products and associated documents on [vegvesen.no](http://vegvesen.no). The Road Directorate reserves the right to change or revoke this compliance letter. Any changes to the product's design or material will void this approval.*

Best regards

Fredrik Nyberg