

FOR NOSEPIECE ATTACHMENT:
REMOVE EXISTING 5/8" Ø BOLTS (4 TOTAL)
AND RE-INSERT THROUGH NOSEPIECE.

EUROTRACC BILL OF MATERIAL

| PART NUMBER | QTY | DESCRIPTION |
|-------------|-----|-------------------------------|
| 25894A | 1 | SHORT EUROTRACC(FULLY ASS'LD) |
| 3310G | 4 | 5/8" LOCKWASHER |
| 4451G | 4 | 5/8" x 6" WEDGE EXP ANCHOR |
| 6051B | 1 | REFLECTIVE TAPE KIT |
| 6532B | 1 | BLACK PLASTIC NOSEPIECE |

EACH TRACC UNIT SHIPS 100% ASSEMBLED
(PLASTIC NOSE INSTALLED AFTER PLACEMENT)

| ** ANCHOR HARDWARE (FULL CONCRETE BASE) | | |
|---|----|--------------------------------|
| 5225G | 12 | 5/8" x 7 1/2" ANCHOR STUD |
| 3310G | 12 | 5/8" LOCKWASHER |
| 3361G | 12 | 5/8" HEX NUT |
| 3300G | 12 | 5/8" FLAT WASHER |
| 5448B | 2 | ADHESIVE HIT HY 150(CARTRIDGE) |

| ** ANCHOR HARDWARE (ASPHALT BASE) | | |
|-----------------------------------|----|--------------------------------|
| 6380G | 12 | 5/8" x 18" ALL THD ROD |
| 3310G | 12 | 5/8" LOCKWASHER |
| 3361G | 12 | 5/8" HEX NUT |
| 3300G | 12 | 5/8" FLAT WASHER |
| 5448B | 4 | ADHESIVE HIT HY 150(CARTRIDGE) |

** SEE PRODUCT MANUAL
★ EACH CARTRIDGE INCLUDES 1 EACH: MIXER HY 150 CARTRIDGE (NOZZLE)
FILLER HIT HY 150 (FILLER TUBE)

OPTIONAL TRACC ANCHOR ITEMS

| PART NUMBER | DESCRIPTION |
|-------------|-----------------------------------|
| 5449B | ADHESIVE DISPENSER |
| 5450B | MIXER HIT HY150 (NOZZLE) |
| 5208B | FILLER HIT HY150 (FILLER TUBE) |
| 5209B | BIT TE-C+ 11/16-18 (11/16" Ø BIT) |

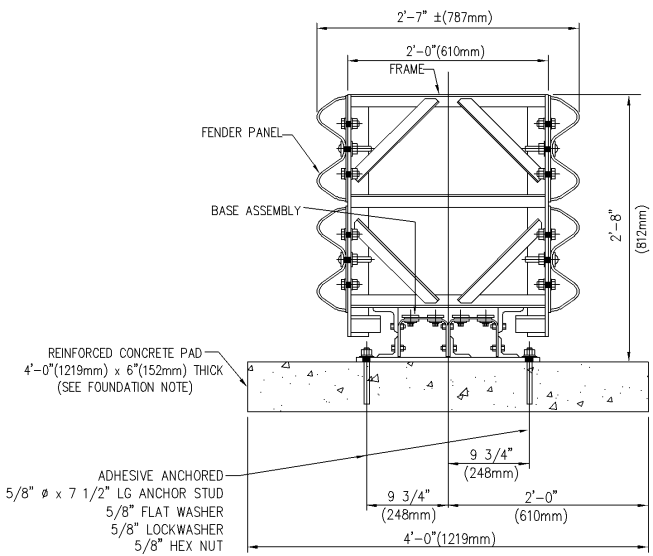

FOUNDATION NOTE:
6"(152mm) REINFORCED CONCRETE PAD IS SHOWN
OTHER OPTIONS ARE :
a) 8"(203mm) THICK MINIMUM UNREINFORCED CONCRETE
b) 8"(203mm) MINIMUM THICK ASPHALT
c) 3"(76mm) THICK (MIN) ASPHALT OVER 3"(76mm) {MIN} CONCRETE
d) 6"(152mm) THICK ASPHALT OVER 6"(152mm) COMPACTED SUBBASE.

| | | | | |
|-----|-------|------|----------|---|
| 2 | BT | LH | 12/16/09 | REVISED HARDWARE |
| 1 | B.T. | L.H. | 3/20/07 | UPDATED TITLE BLOCK; ADDED OVERLAP DIM. |
| REV | CHK'D | BY | DATE | REMARKS |

TRACC

SHORT EUROTRACC 80
CRASH-CUSHION ATTENUATING TERMINAL
PLAN, ELEVATION & SECTIONS
(UNIDIRECTIONAL, DIRECT ATTACHMENT)

TRINITY HIGHWAY PRODUCTS, LLC.

2525 STEMMONS FREEWAY,
DALLAS, TX 75207

| | |
|-------------|------------|
| DRAWN | LH |
| CHECKED | B.T. |
| APPROVED | N.T.S. |
| DATE | 12/14/06 |
| ENG. FILE # | 551070-01E |
| SHT.No. | E1 OF 1 |
| DRAWING NO. | SS 1070 |

© COPYRIGHT © 2006 TRINITY HIGHWAY PRODUCTS LLC
This drawing and the information shown thereon is the sole property of TRINITY H.S.P., INC. Neither the drawing nor such information is to be used for any purpose other than that for which it was specifically furnished by TRINITY H.S.P., INC., nor is any reproduction authorized without written permission.