

PLAN

TRAFFIC

TRAFFIC

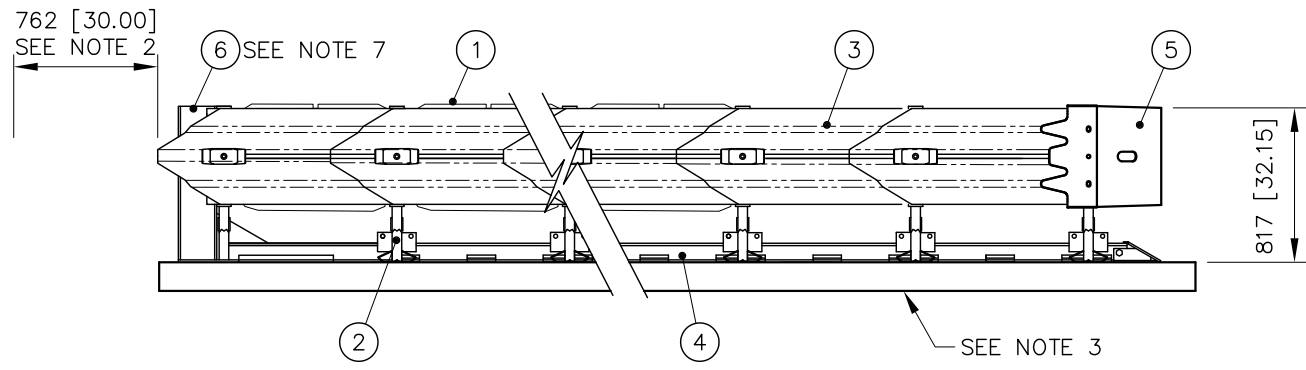

ELEVATION
LEFT SIDE

TABLE

	MODEL NO.	OVERALL WIDTH	SYSTEM WIDTH	SYSTEM LENGTH	EFFECTIVE LENGTH	DESIGN SPEED
5 BAY	QI2405*	810 [32.00]	610 [24.00]	5.22m [17'-1 1/2"]	4.57m [15'-0"]	80 km/h
	QI3005*	965 [38.00]	760 [30.00]			
6 BAY	QI2406*	810 [32.00]	610 [24.00]	6.13m [20'-1 1/2"]	5.49m [18'-0"]	100 km/h
	QI3006*	965 [38.00]	760 [30.00]			
8 BAY	QI2408*	810 [32.00]	610 [24.00]	7.96m [26'-1 1/2"]	7.32m [24'-0"]	110 km/h
	QI3608*	1120 [44.00]	915 [36.00]			

* Y = YELLOW NOSE,
G = GRAY OR GALVANIZED NOSE,
B = BLACK NOSE

- NOTES:
- IN COMPLIANCE WITH THE AASHTO 2002 ROADSIDE DESIGN GUIDE, MANUFACTURER RECOMMENDS REMOVAL OF ALL CURBS AND ISLANDS TO ENSURE PROPER IMPACT PERFORMANCE.
 - PROVISION SHALL BE MADE FOR REAR FENDER PANELS TO SLIDE REARWARD UPON IMPACT 762 [30.00] MIN.
 - FOR FURTHER ASSISTANCE RELATING TO ANCHORAGE OF THE QUADGUARD CEN, PLEASE CONTACT CUSTOMER SERVICE AT (312) 467-6750.
 - SEE THE "QUADGUARD CEN SYSTEM PRODUCT MANUAL", FOR A DESCRIPTION OF ITS IMPACT PERFORMANCE CHARACTERISTICS AND DESIGN LIMITATIONS BEFORE PLACING A SYSTEM AT A GIVEN SITE. INFORMATION AND COPIES OF ABOVE MANUAL ARE AVAILABLE BY CALLING CUSTOMER SERVICE DEPARTMENT AT (312) 467-6750.
 - WHERE NECESSARY, THE CUSTOMER SHALL SUPPLY A TRANSITION FROM THE QUADGUARD SYSTEM TO THE OBJECT BEING SHIELDED.
 - UNITS OF MEASUREMENT ARE MILLIMETERS [INCHES], UNLESS OTHERWISE NOTED.
 - BACKUP AND MONORAIL ASSEMBLIES NOT INCLUDED IN MODEL NUMBER, ORDER SEPARATELY.

UNIDIRECTIONAL
MODEL NO. SEE TABLE

KEY	①	QUADGUARD CARTRIDGE	④	MONORAIL	⑦	BUMPER
	②	DIAPHRAGM	⑤	NOSE ASSY		
	③	FENDER PANEL	⑥	BACKUP		

REFERENCES	
SERIAL#	DIAPHRAGM ASSY. 3540571-0000
SALES ORDER#	FENDER PANEL ASSY. 3540041-0000
	BUMPER ASSY. 3540564-0000
	BACKUP ASSY. 604573
EH PROJECT#	MONORAIL ASSY. 3540060-0CEN
DESIGN SPEED	SEE CHART ABOVE
	BELT NOSE ASSY. 3540550-0000
NOSE COLOR	
NUMBER OF UNITS	

DRAWN:	D. STAUS	DATE:	10/22/99
DESIGNED:	RBB	DATE:	11/01/99
CHECKED:	KRM	DATE:	11/01/99
APPROVED:	RBB	DATE:	11/01/99
CAD FILE:	QCTSCVR-U.dwg		



QUADGUARD® CEN SYSTEM
W/TENSION STRUT BACKUP

Revisions	Date	Rev.	By	Ckd.	App.
REVISED ANCHORING NOTES AND UPDATED DWG AND TABLE, ECO 2528	12/17/08	J	RJV	STT	PLK
ADD STEEL NOSE TO REF, ADD NOSE TO NOTE 7, ADD GALV NOSE, ECO 2869	3/5/10	K	DPH	JME	FJP
ECO 3330; REMOVED STEEL NOSE REF.	3/19/12	L	DDW	JME	KRM