

A-A

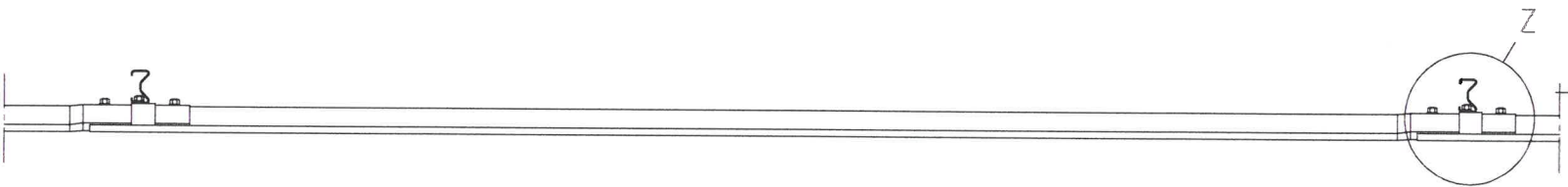

Z 1:5

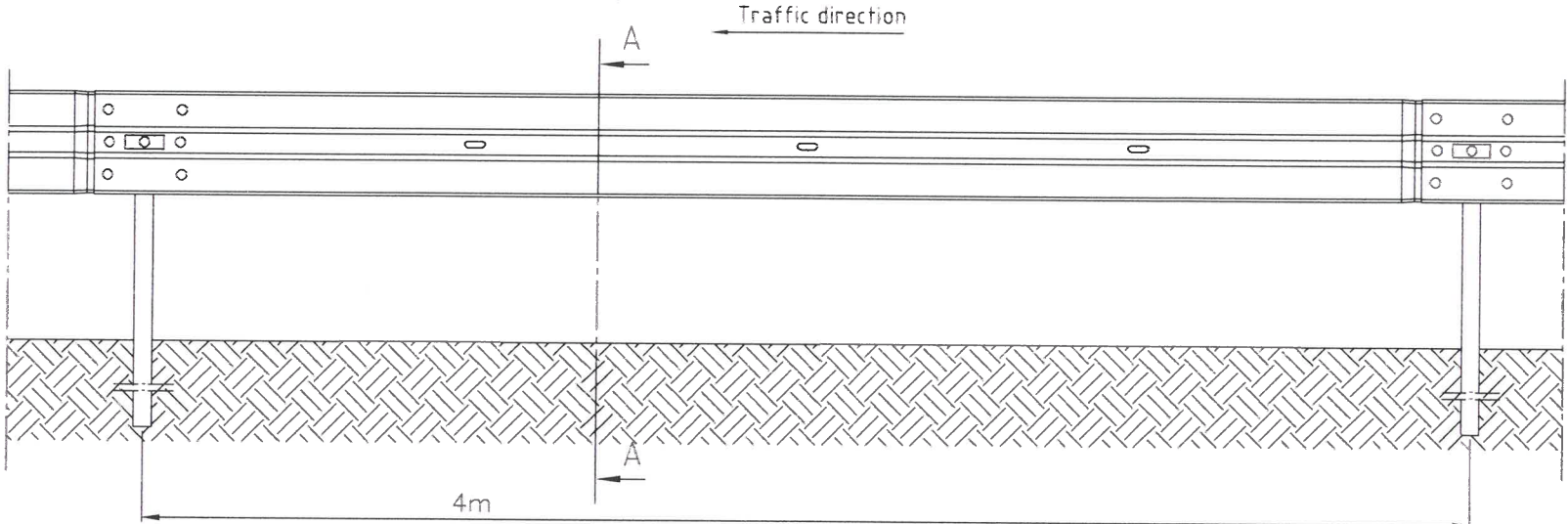
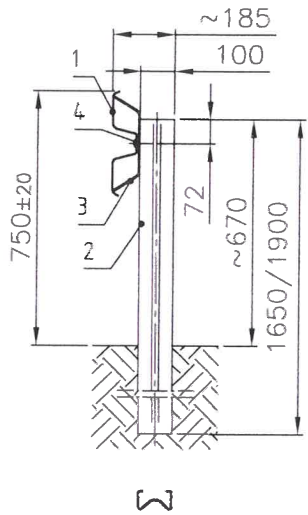
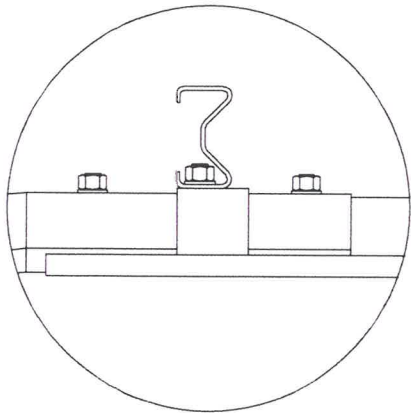

List of elements:

- 1. Guardrail type B (DBO-0101, DBO-0102, DBO-0124)
- 2. Sigma Post 100
L=1650 [mm] (DBO-0356)/
L=1900 [mm] (DBO-0351)
- 3. Bracket type B (DBO-0509)
- 4. Washer M16 (DBO-0513)

Stalprodukt S.A.
ul. Wygoda 69, 32-700 Bochnia
NIP 868-000-07-75, REGON 350008147
KRS 0000055209

Road Barriers Division	Scale 1:15	Design	Date 03.2019	Name R.Nakoneczna	Signature
	Material	Checked	03.2019	M.Piechnik	
	Amount	Approved	03.2019	M.Faron	
	Change	a*			
Drawing name SP-05/4-single section	Mass	b*			
		c*			
Archive index	Number of drawing	Sheet No	Change drawing No		
	MD/25/2019	Amount	Substituted by		
STALPRODUKT S.A.					