

<i>Stalprodukt S.A.</i>	Kind of document : <b>Assembly manual</b>	Reference No: <b>IM/DP-3/11</b>	
Title : ASSEMBLY MANUAL OF ROAD SAFETY BARRIER SP-15/4 according to EN 1317-5:2007+A1:2008 pkt 8		Page: 1	Issue No: II
		Pages: 3	

	Position	Name	Signature	Date
Developed	Engineer PT	Pałkowski Dawid		09.05.2011
Checked	Manager KJ	Browarski Stanisław		09.05.2011
Approved	Director DP	Tyka Krzysztof		09.05.2011

### Documentation of the producer

According to EN 1317:5 standard point 5.2 Product description

### Equipment and employees

The Contractor should produce evidence that he has the possibility to use special equipment to assemble and transport barriers, which is safe to use. The team performing road works should be under continuous supervision, executed by a properly qualified employee. The Contractor shall equip employees with means of individual protection. Vehicle marking and protection of the working place should be compliant with current legal regulations binding in the place where works are performed.

### Materials

Materials should be compliant with requirements stated in Documentation of the Manufacturer.

Individual barrier elements are packed in bundles with size depending on the weight of elements and the size of the commission. Small barrier elements are delivered in containers or cases.

Each bundle or case shall have a tag including at least the following information:

- name and address of the producer,
- name of the product, together with the name and marking of the element,
- date of production,
- weight of the bundle, container or case,
- number of items in one delivery

Barrier elements should be stored in places and conditions, in which they shall not be exposed to mechanical defects or intensive corrosion.

### Stages of assembly works

Assembly works include the following stages:

- 1) **Preparatory works and measurements** (indication of barrier road with verification of the course of underground installations, determination of posts location, indication of possible passage routes, crossings as well as final and initial barrier sections)

<i>Stalprodukt S.A.</i>	Kind of document : <b>Assembly manual</b>	Reference No: <b>IM/DP-3/11</b>	
Title : ASSEMBLY MANUAL OF ROAD SAFETY BARRIER SP-15/4 according to EN 1317-5:2007+A1:2008 pkt 8		Page: 2	Issue No: II
		Pages: 3	

- 2) **Placing posts of the protective barriers system** – placing posts within the distance from the edge of the road stated in Project Documentation. During this stage of works it is essential to verify settlement, height and distance between posts. In case when placing posts of protective barriers system shall be executed by vibrating, due to cyclical blows of the pile-driver head on the head of the post, deformation and partial damage of the galvanized layer on the post is allowed. The scope of deformations and damages of the galvanized layer depends on the soil class and the degree of its concentration. This is a common phenomenon and therefore it does not signify the quality of works. In such cases the damaged galvanized layer is repaired with zinc paint. The deformed head of the post cannot be cut.
- 3) **Assembly of protective barriers system** – Assembly of protective barrier elements should be made according to Documentation of the Producer and Project Documentation. When assembling protective barriers system it is forbidden to make any holes or cuts violating the galvanized layer of particular elements. Assembly of protective road barriers includes:
  - a) assembly of distancing elements within the protective barriers system with the use of appropriate joining elements,
  - b) assembly of guides for distancing elements with the use of appropriate joining elements. During this stage of works adjoining segments of guides need to be connected according to the direction of vehicle movement, in a way, which in case of accident will enable the vehicle to slide along protective barriers system without touching edges of the guides,
  - c) assembly of initial and final segments of protective barriers system
  - d) regulation of joining element's tightening moment
  - e) checking the continuity of galvanized surface and repair of possible damages
  - f) fixing reflective elements on protective barriers system.
- 4) **Quality control of the works** should include:
  - a) verifying the compliance between the assembly of protective barriers system with Project Documentation and Documentation of the Producer, with consideration of possible size deviations,
  - b) test of galvanized layer thickness and its appearance
- 5) **Site arrangement**

<i>Stalprodukt S.A.</i>	Kind of document : <b>Assembly manual</b>	Reference No: <b>IM/DP-3/11</b>	
Title : ASSEMBLY MANUAL OF ROAD SAFETY BARRIER SP-15/4 according to EN 1317-5:2007+A1:2008 pkt 8		Page: 3	Issue No: II
		Pages: 3	

### Technical specification for road restraint system SP - 15/4 on ground:

Steel quality: S235JR in accordance with EN 10025-2

Hot-dip zinc coating:

-in accordance with EN ISO 1461

-continuous method according to EN 10346

Bolts:

Bolts in accordance with EN ISO 898-1:

- M 10 x 40 according to EN ISO 4017; property class 8.8
- M 16 x 25 according to drawing (appendix); property class 4.6

Nuts according to EN ISO 4032

Washers according to EN ISO 7091

Tightening torque of the bolts:

- M 10 - T =  $50 \pm 10$  [Nm]
- M 16 - T =  $70 \pm 10$  [Nm]

Sequence of assembly in accordance with attached drawings:

SP-15/4 - Assembly drawing safety barrier SP-15/4

SP-15/4 - Road barrier SP-15/4 (Single section)

SP-15/4 - Terminal for system SP-15/4

SP-15/4 - Single side safety barrier SP-15/4

SP-15/4 - Assembly of bolt M10x40 for system SP-15/4

Bolt M16xL

The tolerance for height of the top of the system is  $\pm 20$ mm.

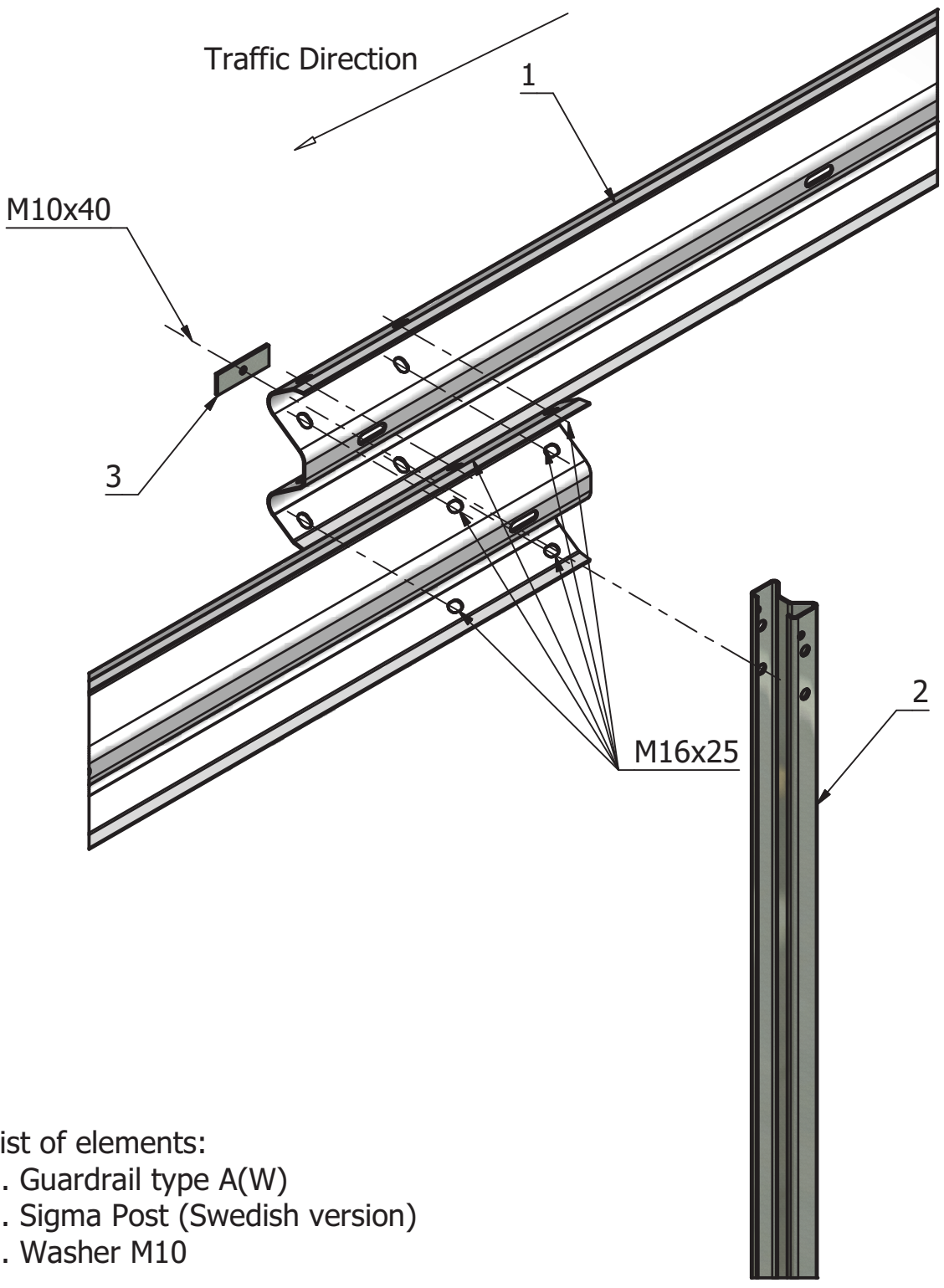

- List of elements:
- 1. Guardrail type A(W)
  - 2. Sigma Post (Swedish version)
  - 3. Washer M10

<b>Road Barriers Division</b>		Scale	<b>1:10</b>		Design	Date	Name	Signature
		Material	-	Checked	05.2011	D.Palkowski		
			Approved	05.2011	K.Pobiedacz			
		Amount	-	Change	a x			
b x								
c x								
d x								
Drawing name	Assembly drawing safety barrier SP-15/4	Mass	-	<b>INVENTOR</b>		Change drawing No		
	Archive index	Number of drawing		Sheet No	1	Substituted by		
		SP-15/4		Amount	1			
<b>STALPRODUKT S.A. - BOCHNIA</b>								

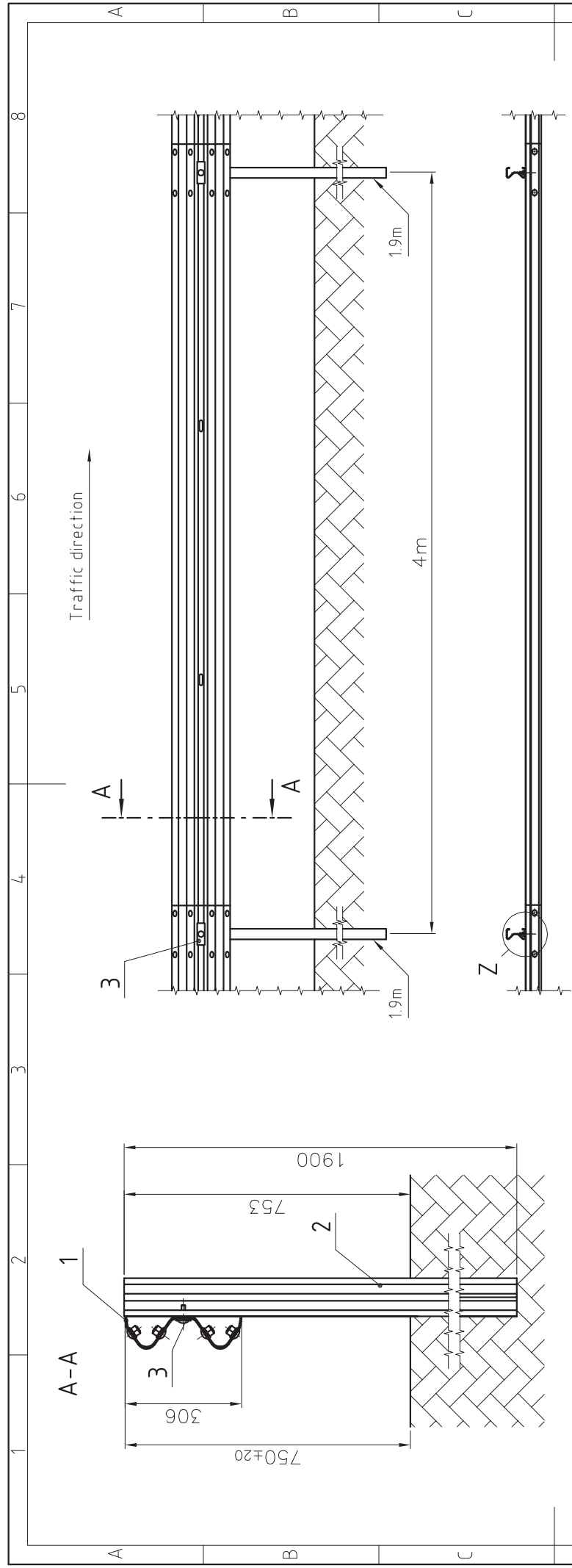

- List of elements:
1. Guardrail type A(W)
  2. Sigma Post (Swedish version)
  3. Washer M10

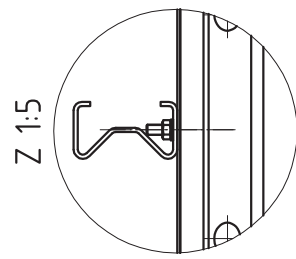

Road Barriers Division	Scale	1:20	Date		Name		Signature
	Material		Design	05.2011	D. Palkowski		
	Amount		Checked	05.2011	K. Pabielutz		
Drawing name Road Barrier SP-15/4 (Single Section)	Mass	Number of drawing SP-15/4	Approved	05.2011	K. Lyka		
			a*				
			b*				
			c*				
Archive index	Change drawing No	AutoCAD					
		Sheet No		Substituted by			
Amount							
STALPRODUKT S.A.							

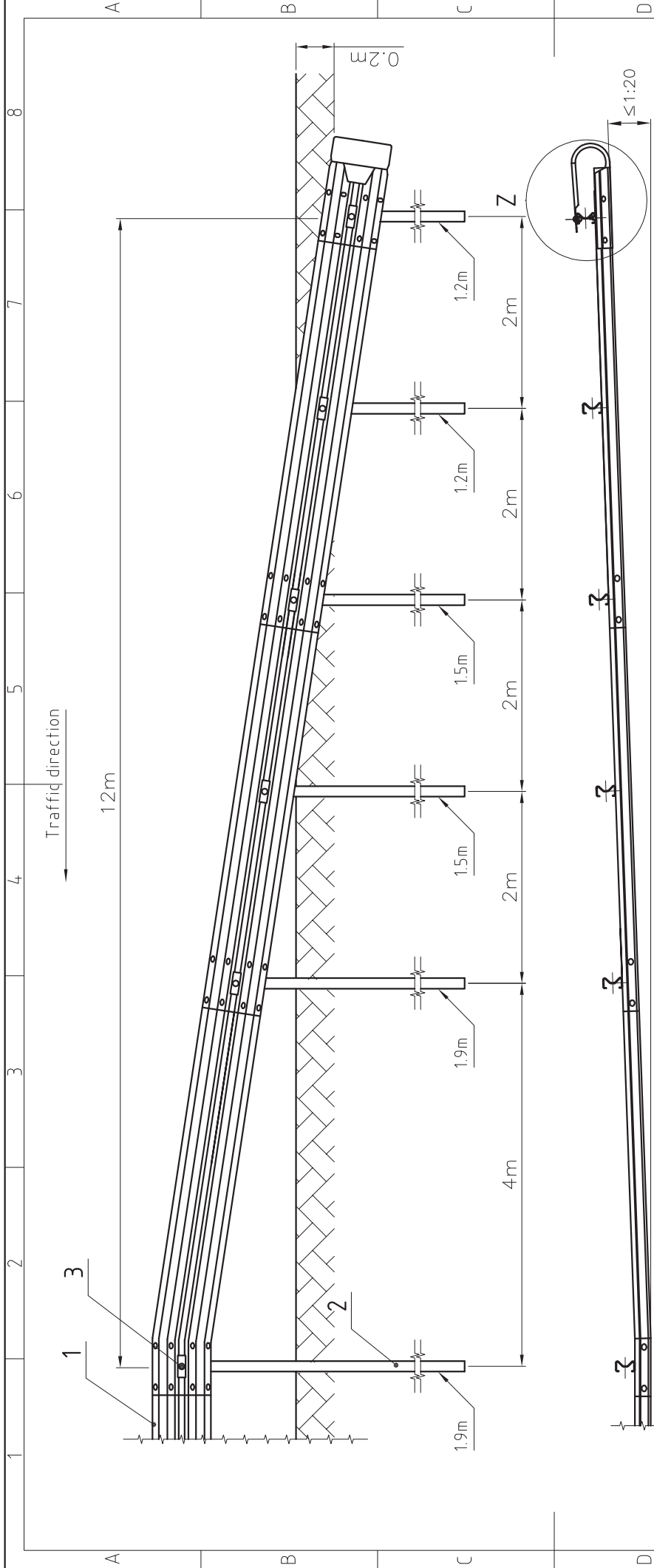

List of elements:

1. Guardrail type A(W)
2. Sigma Post(Swedish version)
3. Washer M10
4. Frontal single joining piece A(W)

Z 1:8

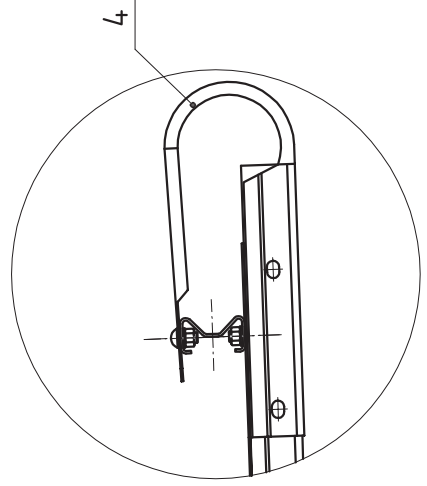

Scale		1:20		Date	Name	Signature
Material		Design	05.2011	D.Palkowski		
Amount		Checked	05.2011	K.Pabielutz		
Mass		Approved	05.2011	K.Lyka		
		a*				
		b*				
		c*				
		d*				
Drawing name		AutoCAD		Change drawing No		
Terminal for system SP-15/4		Sheet No		Substituted by		
Archive index		Amount				
Number of drawing		SP-15/4				
STALPRODUKT S.A.						

Traffic direction

12m

A

B

C

D

E

F

0.2m

1.2m

2m

1.2m

2m

1.5m

2m

1.5m

2m

1.9m

2m

4m

1.9m

$\le 1:20$

Z

3

3

3

3

3

4

1 2 3 4 5 6 7 8

1 2 3 4 5 6 7 8

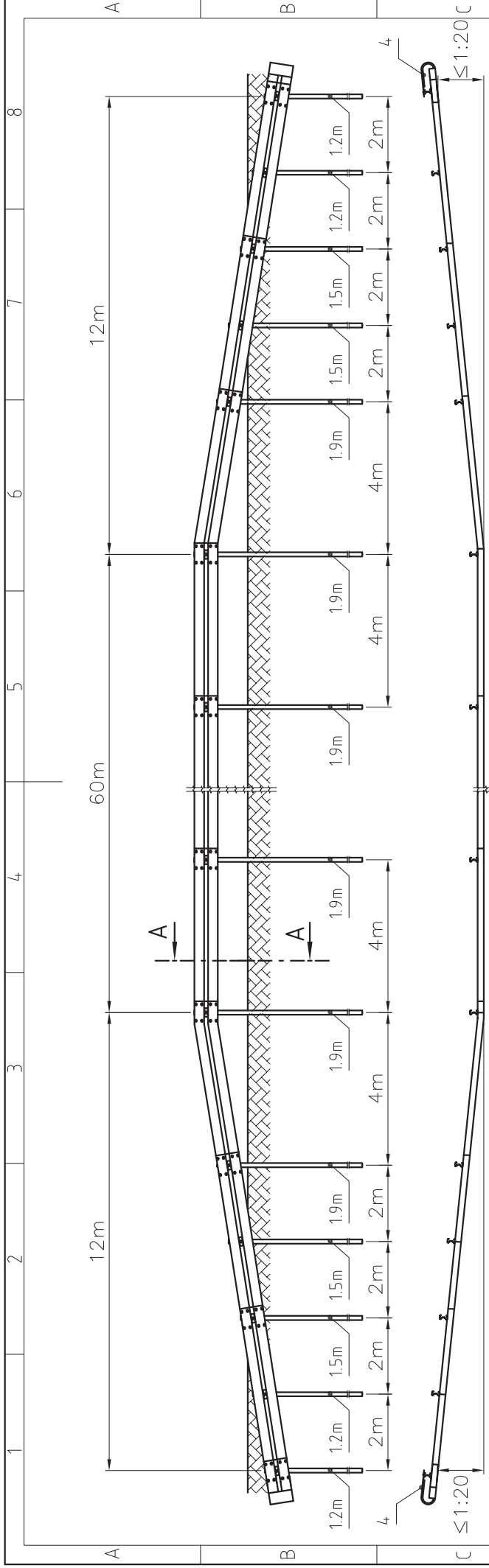

List of elements:

1. Guardrail type A(W)
2. Sigma Post(Swedish version)
3. Washer M10
4. Frontal single joining piece A(W)

A-A

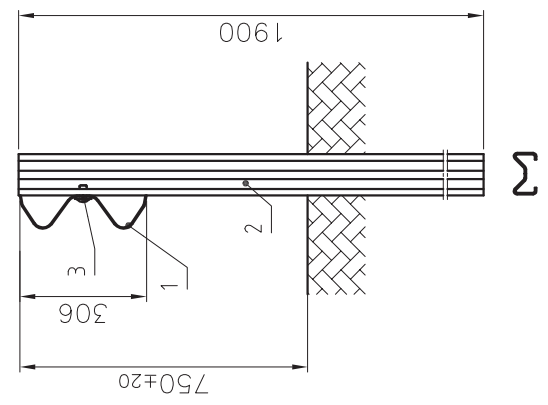

Road Barriers Division		Scale	1:100	Design	05.2011	Date	05.2011	Name	D.Palkowski	Signature
		Material		Checked	05.2011	Approved	05.2011	K.Pabiedzki		
		Amount		a*		b*		c*		
		Mass		d*						
Drawing name		AutoCAD								
Single side safety barrier SP-15/4		Change drawing No								
Archive index		Number of drawing		Sheet No		Substituted by				
SP-15/4		SP-15/4								
STALPRODUKT S.A.		STALPRODUKT S.A.								

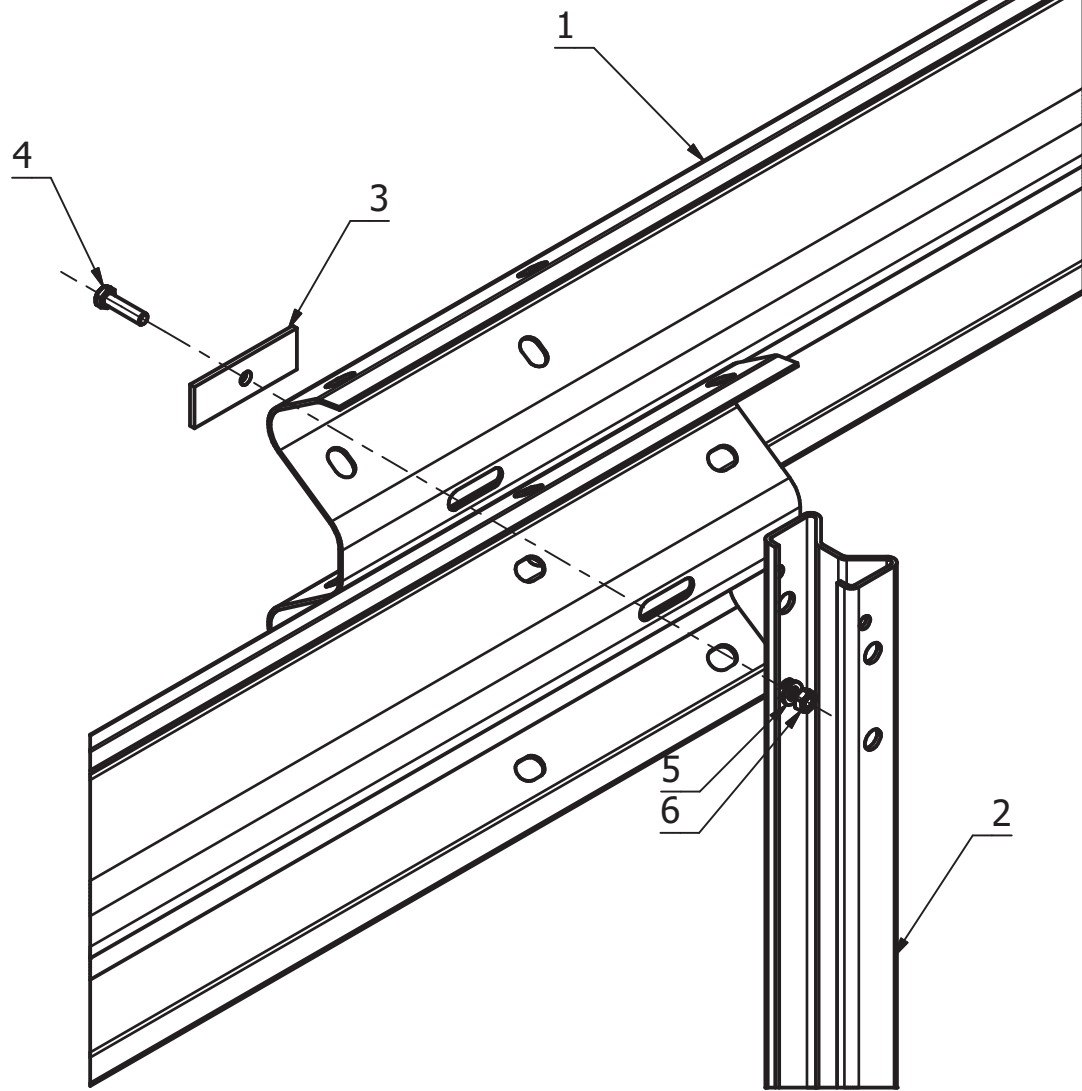

List of elements:

1. Guardrail type A(W)
2. Sigma Post (Swedish version)
3. Washer M10
4. Bolt M10x40
5. Round Washer
6. Nut M10

<h2>Road Barriers Division</h2>		Scale	1:6	Design	Date	Name	Signature
		Material	-	Checked	05.2011	D.Palkowski	
				Approved	05.2011	K.Pobiedacz	
		Amount	-	Change	a x		
b x							
c x							
d x							
Drawing name		Mass	-	INVENTOR		Change drawing No	
Assembly of bolt M10x40 for system SP-15/4							
	Archive index	Number of drawing		Sheet No	1	Substituted by	
		SP-15/4		Amount	1		
<b>STALPRODUKT S.A. - BOCHNIA</b>							



# BOLT M16 x L

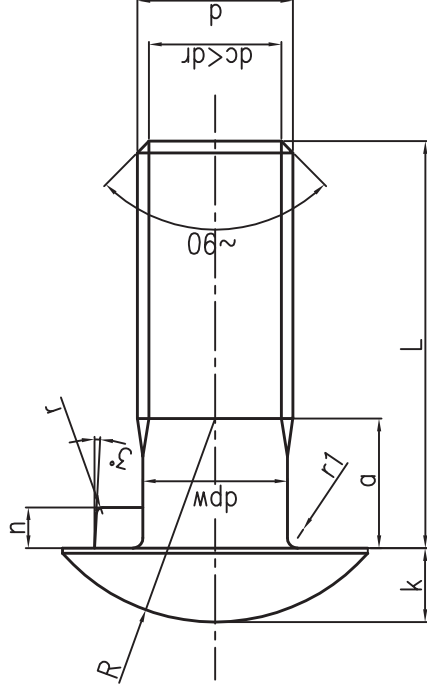
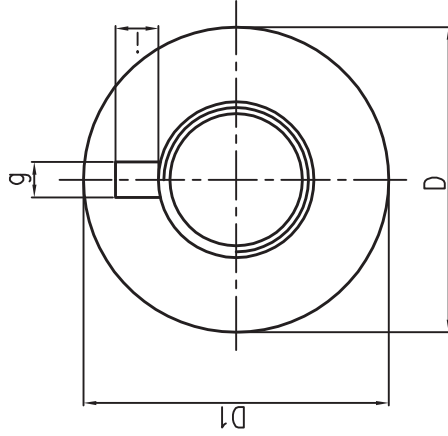

Dimension	Thread	M16
L		25 or 40
d	min	15.235
d	max	15.685
dp	min	14.02
dp	max	14.22
dr	min	12.904
dr	max	13.231
dpw	min	14.73
dpw	max	14.20
r	max	1
D	min	29.35
D	max	30.65
D1	min	29.0
D1	max	29.5
k	min	7.55
k	max	8.45
R	~	20.0
g	min	3.25
g	max	3.8
n	min	4.0
n	max	4.2
i	min	4.2
r1	~	0.6
a	max	-
dc	max	13.0

Road Barrier Division		Scale	2:1
Material		-	
Amount		-	
Mass		-	
Drawing name Bolt M16 x L			
	Archive index	Nr of drawing	
		M 1 6 x L	
Nr sheet Amount		Substituted by	

® Stalprodukt S.A. – Bochnia