

Detailj 1 tegn. nr. SW2-010

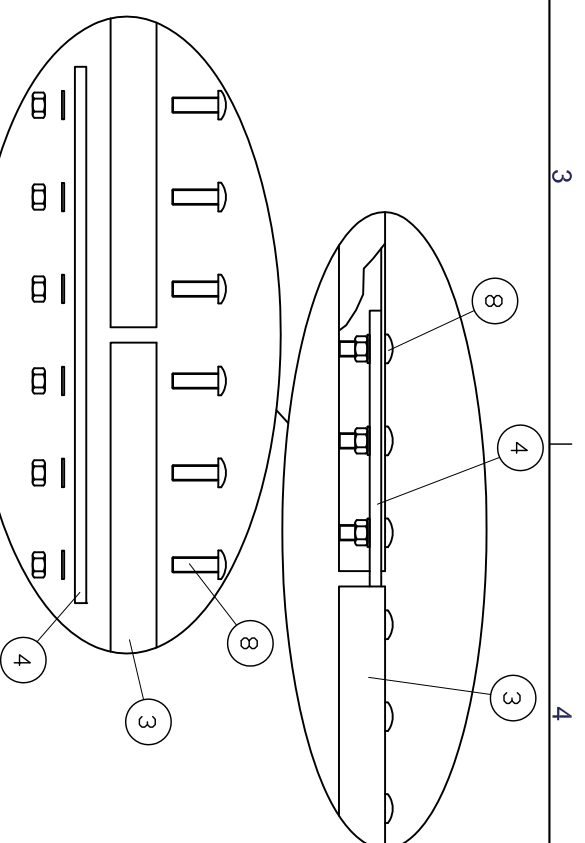

Detailj 2 tegn. nr. SW2-010

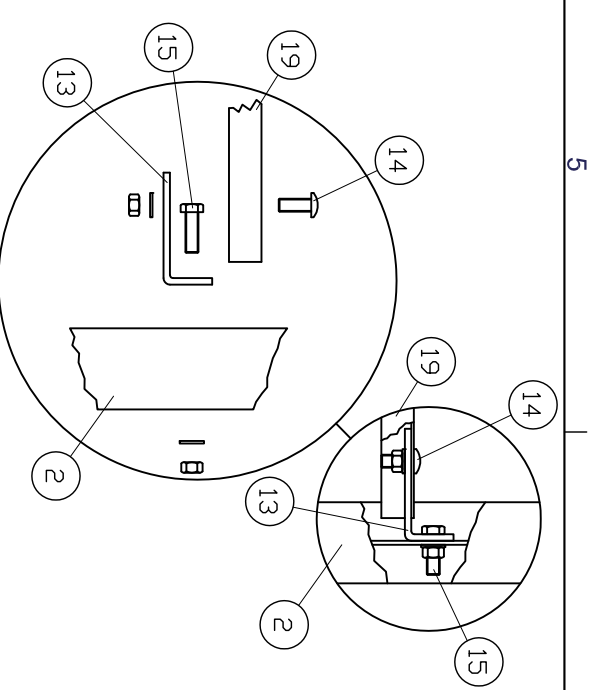

Detailj 3 tegn. nr. SW2-010

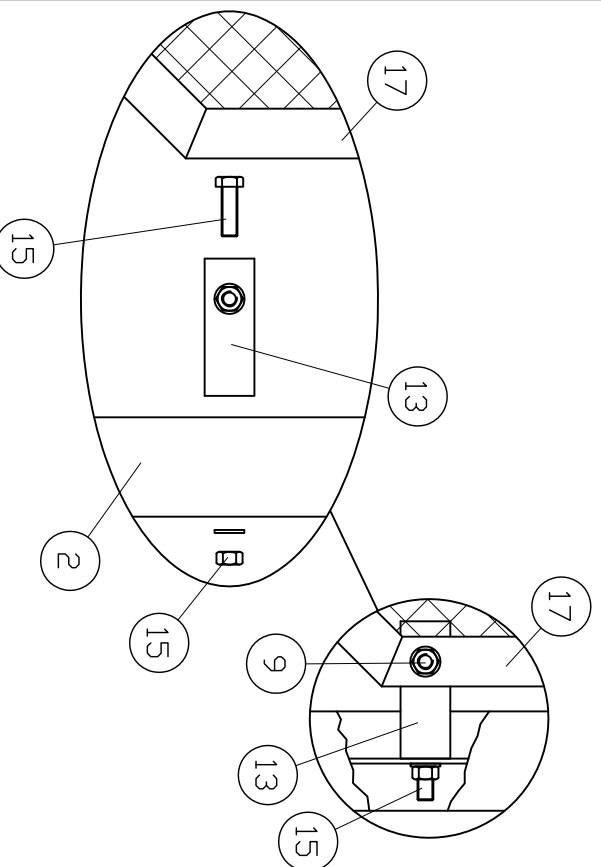

Detailj 4 tegn. nr. SW2-010

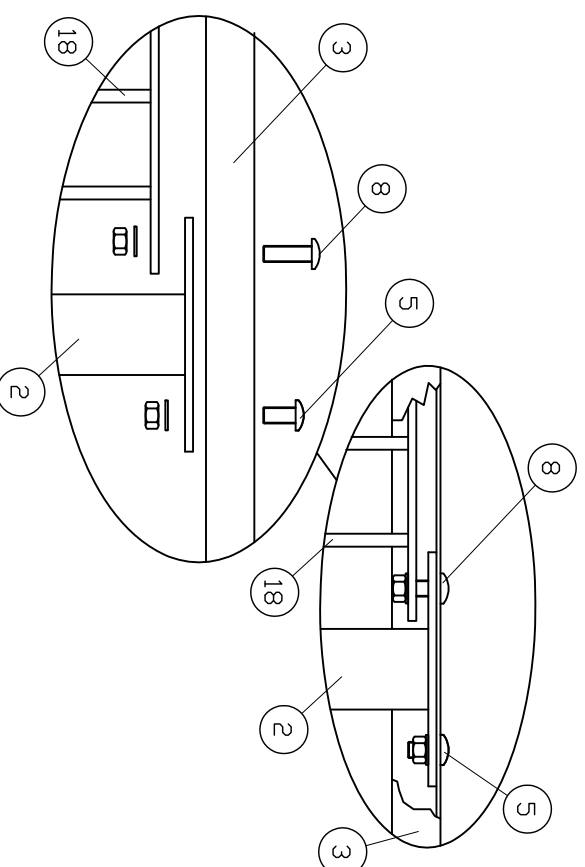

Detailj 5 tegn. nr. SW2-010

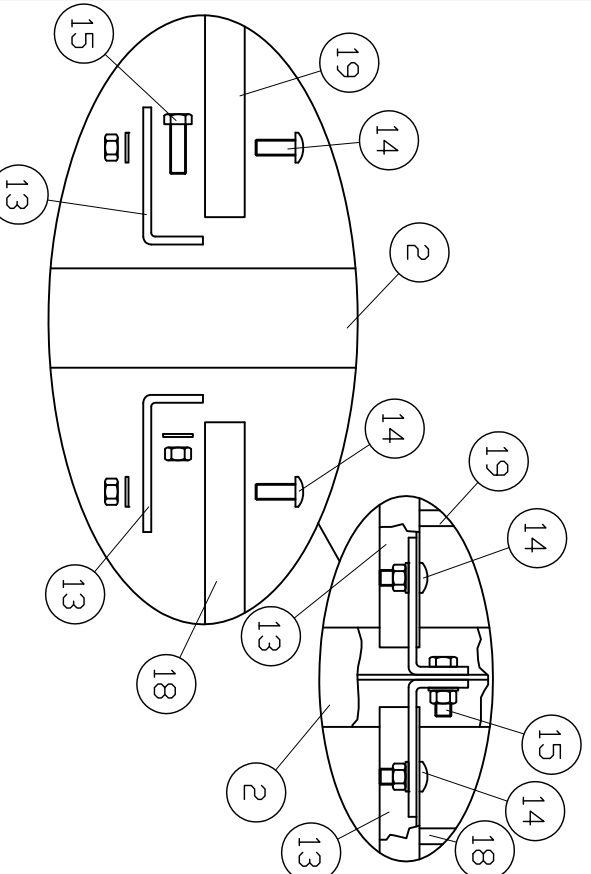

Detailj 6 tegn. nr. SW2-010

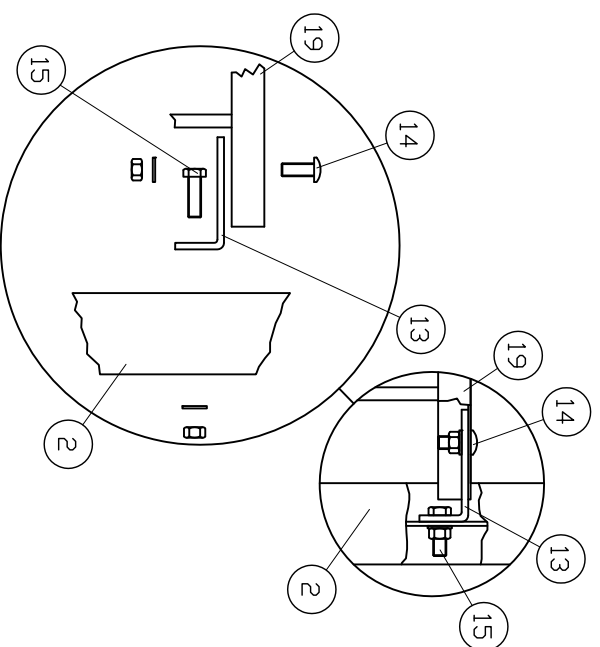

Detailj 7 tegn. nr. SW2-010

20	62301	Rekkv. stole SVV fotpl. Ø28	31,9			
20	62300	Rekkv. stolpe SVV fotpl. Ø24	31,9			
19	62363	Sprossepanel SVV lavt for kantdr.	35,6			
18	62360	Sprossepanel SVV høyt for kantdr.	48,1			
17	62352	Panel brøytelett SVV ftkantdr.	23,3			
15	60807	Festeskrue M16x50 Vfz. kpl.	0,2			
14	62400	Skrue 4kt. M16x40 Vfz. kpl.	0,2			
13	62335	Brakett for SVV1/SVV2	0,7			
12	62350	Panel SVV KFJ60x40x3, L=1940	6,4			
11	60640	Sk. skrue M16x25 kpl.	0,1			
10	60981	Skive M16 115x40x5	0,2			
9	60806	Festeskrue M16x40 kpl.	0,1			
8	62420	Skrue 4kt. M20x60 Vfz. kpl.	0,3			
5	62419	Skrue 4kt. M20x40 Vfz. kpl.	0,2			
4	62225	Skjøtelask for håndlist SVV2	13,7			
3	62220	Håndlist KFJ 140x60x6, L=5980	56,0			
2	62306	Stolpe for kantdrager m/fotp. hull Ø24	27,9			
Pos	Ant.	Art. nr.	Materialtype	Kapl.	Vekt	Anm
Dato	21 nov. 2013	Konstr./Tegnet	JHS	Målestokk	A3	
Beregning		Godkjent				

KJØRESTERKT BRUREKKEVERK TYPE

VIK-SVV2

Detaljer 1-7

Henvising:



VIK-SVV2-020

Revisjon

-

c:\systemtegning\vik-svv2-020.dwg

Denne tegning er vår eiendom og må ikke, uten vårt samtykke, brukes, kopieres eller noen andre interesser gøres tilgjengelig for andre.